

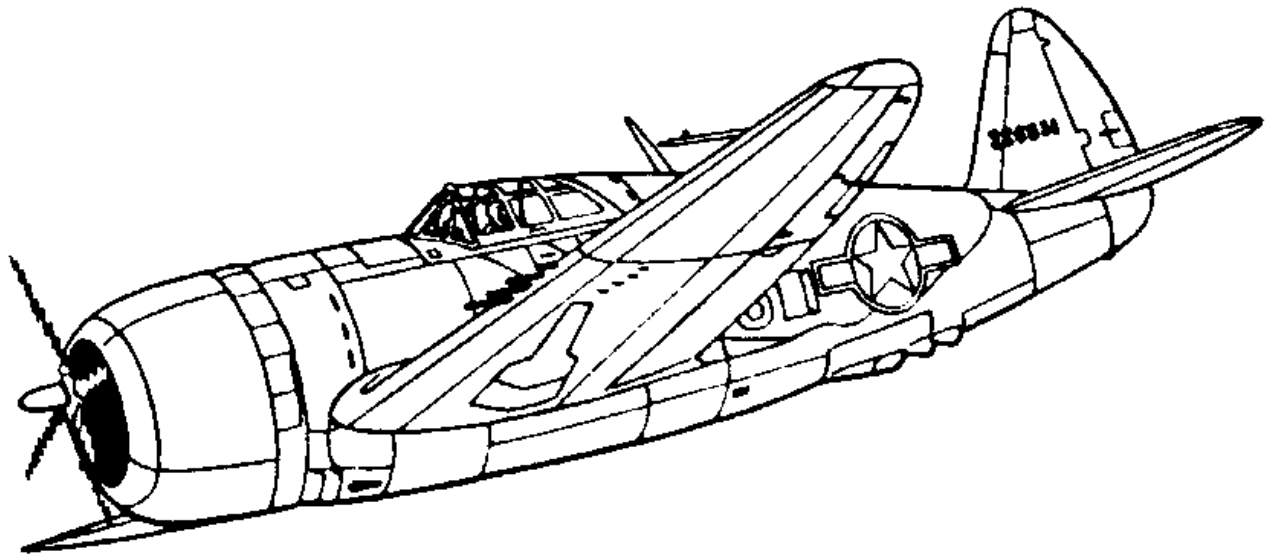

# 102" REPUBLIC P-47 THUNDERBOLT BUILD INSTRUCTIONS



# THIS IS A VERY EASY PLANE TO BUILD

## **BEFORE YOUR START**

The fuselage self-jigging system used allows easy accurate assembly. But, attention to detail when cutting the parts from your patterns is very important.

## **SUGGESTIONS FOR PARTS ACCURACY**

1. Cut the patterns to within 1/4" of the outside lines.
2. Attach to the selected wood with scotch tape.
3. Use a #11 blade to punch through the patterns. Every few inches, place scotch tape over the cut area. When done, you still have the patterns to verify your finished parts. If you acquire a desk style scotch tape dispenser it will be a great asset now and in the future.
4. Alternate methods used are of carbon paper over the wood, or "SEE TEMP" to make separate patterns while preserving the originals.
5. After cutting out the bulkheads, make a 1/4" x 3/8" x 1" piece of balsa to be used as a depth gauge. Check all notches in the bulkheads for proper depth. (Same for wing rib notches.)

## **REMOVAL, ASSEMBLY AND INSTALLING THE WHITE PLASTIC PARTS**

1. A small pair of tin snips is an excellent choice for accurate and easy cutting along the separation lines. A razor saw is good for straight cuts.
2. When ready to install the several plastic parts to the fuselage, tape the parts in place. Use thick C.A. to glue. DO NOT use kicker as it will attack the plastic. BELIEVE!

## **CANOPY**

1. When canopy has been fitted and exactly in place on the fuselage, install some pins next to the front windshield, along the bottom of the sides and at the rear to facilitate exact location when gluing the canopy down. Note: Recommend five-minute epoxy or R/C 56 glues. Do Not Use C.A.

## WING INSTRUCTIONS

Note: This wing design has a flat bottom, thus no need for jigs, etc. However, you will need a flat surface to build your wing. If you don't have a suitable surface, find an inexpensive hollow door from your local Home Depot or building supply store. Use a level to insure no twist exists.

1. After all ribs have been cut out, do yourself a favor. Check all spar notches for exact depth and width NOW! Make up the "spar brace" now. It should be just under 3/4" wide. Make from basswood or equivalent. Write left and right on each end.

Note: The 3/8" x 3/4" spar material must all be of the same width (3/4") in order for the shear webs to fit flush to the bottom, mid and upper spars. Check this now.

2. Make up the main rear spars now. There are 2 lefts and 2 rights, so go slow. The 1/4" x 3/8" spars install to the bottom of the wing (see rib notches).

Note: This wing is framed directly on the plans without any sheet. The wing sheet panels are shown with dotted lines and are made up after complete wing framing is complete. The flaps (optional) and ailerons are fabricated away from the main wing plans.

3. Epoxy the W-5A and W-7A doublers to the W-5 and W-7 ribs. Remember to make up two lefts and two rights as the "A's" face each other. Important!
4. Pin in place the main and secondary spars. Also the flap FH-1 and aileron AH-1 headers.
5. Install all ribs now. Be sure that they all touch the work surface. Adjust notches as needed.
6. Loosely install the top spars. Use a 48" straight edge to check that the spars are seated into the notches and have no high spots. Adjust as needed. Do not glue yet.
7. Install the single piece 3/32" balsa shear web's to center of both bottom spars between ribs W-7 and W-12.
8. Put in place the two top spars. Check for high spots. Trim the shear webs as needed. With the spars straight glue in place.
9. Install front and rear vertical grain 3/32" shear webbing to the secondary spar.
10. Install the 3/32" vertical grain shear webbing to the front only of the main spar W-1 thru W-7.

## WING SEPARATION FEATURE

11. Place your "Spar Brace" in place against the bottom spar. Wedge in place. Be sure the centerline on your "Spar Brace" is lined up with W-1. (Note: If you want a one piece wing, glue the "spar brace" to the bottom spar.)
12. Cut the mid spar pieces 3/8" x 3/4" stock to 3-7/8" long. Place against the top of "Spar Brace" and against the front shear web. Apply a small amount of thick C.A. to each end where it touches the W-5 and W-6 ribs. When set remove the "Spar Brace" to insure that the glue did not contact the "Brace."
13. Reinstall spar brace and repeat above until all mid spar pieces are in place. Note: The piece between W-1 and W-2 has to be shaped in order to fit in place.
14. Remove spar brace. Thoroughly glue (C.A.) all mid spar pieces to the front web and ribs.
15. Now install the shear webs to the back of the main spar. Use thick C.A. and not so much that it runs inside of cavity.
16. Watch for glue running into "Spar Brace" cavity. Remove any globs.
17. Install the spar brace and check fit. It must enter to a depth of the centerline. Did you put the proper left-right side into the wing when doing the mid spar assembly? If not, change the designation (reverse the left right).
18. Install the "G.P." (Gear Plate) and two "G.B." (Gear Blocks) to W-5, 6, & 7. Install 1/4" thick by 3/8" balsa to top and bottom of "G.P." at W-5 & 7.
19. Install the "Wing Tongue" to front of W-1-2. Use 30 Minute Epoxy.
20. Pin the 1/8" L.E.-2 to front of ribs with the top edge even with the top front of the ribs. Use your straight edge to check for ribs that are too long. Trim. Glue in place. Sand to an angle that part of L.E.-2, which flows into rib contour.
21. Install the W.P.B. 1/8" ply part between W-1 and W-2 behind the flap header. Install the 1/8" balsa F.H.-2 to F.H.-1. This part ends flush with top of ribs (see plans).
22. Your retracts should be installed now if you are going to use bolts and blind nuts. If you plan on using sheet metal screws you may proceed. The flap actuators are also installed NOW!

23. Make up 4 “A”-“B” wing sheet parts. Glue the “B”s to the “A”s. (You will have to add on a 1” extension to the “A” and “C” sheets.) (Do this to the tip end.)
24. Make up 4 “D” and “E” sheets. Glue together. The “E” sheet is cut to size of “E” template shown.
25. The top and bottom “C” sheets are now installed. The front of these panels centers on to the secondary spar (front). Note: When cutting the edges so that they are straight, be sure the width of “C” sheet is 3 15/16” wide when done.
26. The “D”-“E” panel is trimmed so that the rear edge centers onto the 1/4” x 1/4” spar before gluing in place. The “H” panel (3/32” bal with 1/32” ply laminate) butts to the rear of “D”-“E” panel. See side view of flap detail and detail shown on right wing plan.
27. Make up “E” panel and sand angle to it as shown on side view of flap. Lay aside.
28. For proper flap fit to the wing it is important that the rear edge of the “E” sheet centers on the 1/4” x 1/4” spar. Doing so properly positions the “H” panel in relation to flap.  
  
Note: Do not install the “D”-“E” sheets until flap actuation system is decided on. We only show the system we think is most appropriate. You may actuate the flap in same fashion as ailerons if you like.
29. Proceed to build ailerons and flaps. Suggest that you install flap hinges (Dubro #257 suggested) before installing the “H” panel to wing.  
  
Note: The flap activators shown will work with standard 70 oz. servos. However, 180° proportional servos would be a better choice. In order for the aileron to operate freely when the flaps are down, you will have to angle sand the end of the aileron. This will not be noticed from above.
30. See plans instructions for aileron and flap building instructions.

### **HORIZONTAL STAB INSTRUCTIONS**

1. Draw a straight line on your workbench 36” long. Center both S-9’s onto this line. Glue the S-10 onto the S-9’s. Pin the assembly to your work surface in a convenient place to work.
2. Be sure you have the 90° braces on hand. Glue the two W-1’s together. Put rib location marks onto the S-8’s and S-9’s NOW.
3. Pin the W-1s in place (onto the S-10). Install the 90° brace in place – glue base to S-10.

4. In order to use a square to align the W-1's you will need two pieces of 1/8" balsa under one end of the square to level it with the top of S-10. A centerline on the W-1's helps with alignment.
5. Repeat step 3 and 4 to install S-6. Be sure you install the hinge blocks now.
6. Install S-8's.
7. Install all ribs now. Be sure that they are not over length, as they will cause a bow in the S-8's (use a straight edge along S-8 at this time).
8. Important: Install the inboard hinge blocks NOW! Don't forget!!
9. Sand an angle to top and bottom of S-8's to match the flow of the ribs. Same for S-9's.
10. Make up 4 "A" "B" 1/8" balsa panels. Join the "B"s to "A"s and the scrap parts to the "B" parts. These panels should be 1/8" larger than the frame.
11. Trial fit the panels to stab frame. Trim inboard edge so that it centers on the W-1's.
12. In order to avoid warping of the stab frame, it is advisable to install the top and bottom panels at the same time. Do this as follows.
  - A. Pin both panels to S-8 being sure that they center on W-1s and overhang the S-8 by 1/16". Now glue to S-8.
  - B. Apply white glue to all ribs.
  - C. Pull both panels down onto frame and C.A. rear edges to the S-9.
  - D. Sand the panels flush with the S-8 and S-9.
  - E. Install the 3/8" x 1/2" leading edge. Shape.
  - F. Install S-7 tips. Do not shape these yet.
  - G. Reinforce the center section with 1" wide reinforcing tape and thick C.A. or your choice of glues. IMPORTANT!

### **ELEVATOR INSTRUCTIONS**

1. Using template supplied make up 4 1/16" balsa "E"-9 elevator parts.
2. Lay one onto the plans and pencil mark rib locations onto the "E"-9. Do the same onto the right side "E"-9.

3. Glue the “E”-8 in place being sure it is 90° to “E”-9. You might use the hinge blocks to assure this. Be sure the 1/8” x 1” ply control horn plate is in place.
4. Install all ribs.
5. Use a large sanding block to angle sand from the “E”-8 to the trailing edge of the “E”-9. See cross section of elevator. If you want a scale like edge at the trailing edge you should sand the E-9 down to about 1/32” thick or less.
6. Angle sand the top “E”-9 at its trailing edge. Same as bottom “E”-9. Cut away that portion that overhangs the E-1.
7. Note: When top E-9 is in place the trailing edge will be slightly forward of the bottom “E”-9 edge. This allows easy C.A. application in this area.
8. When top “E”-9 is in proper position apply C.A. to trailing edge area between “E”-2 and “E”-4.
9. You can pry the “E”-9 away from the frame in order to apply white glue to ribs and the rest of frame. Use masking tape to hold down while glue dries.
10. Install “E”-6 tip blocks. Sand close.
11. Hinge elevator to stab.
12. Apply masking tape to both sides of hinged area to hold elevator straight. Now sand the stab and elevator tips to shape.

### **VERTICAL FIN AND RUDDER**

1. The vertical fin assembles the same way as the stab.
  - A. Pin the F-2 to work surface.
  - B. Install the two 90° braces next to proper rib locations.
  - C. Install F-4 & F-8 ribs – be sure they are 90° both ways.
  - D. Install balance of ribs. Do not force them, as they will cause F-1 to distort.
  - E. From the supplied templates make up the fin sheet from fin sheet 1, 2 and 3 templates.
  - F. These fin sheet parts must install flush to top of F-8 and F-2. The lower edges will eventually be trimmed to fit the top of the horizontal stab.

## **RUDDER**

Note: All control surfaces on the full scale had their trailing edges end in a thickness of 1/16". In order to duplicate this, a bit of patience is needed in properly sanding to the correct angle the two cover sheets and the center R-3. Study the cross section before proceeding. Decide now if you want to hinge in scale fashion.

- A. Make the R-3 and R-1 parts. Both should be as hard as you have on hand. Should be "C" grain.
- B. To locate the R-1 onto the R-3, position the 3/8" x 3/4" x 16" block "A" to front of R-3 then place the R-1 next to the block "A." Glue R-1 only. Remove the Block "A" – One side only.
- C. Make up ribs from scrap 1/8" balsa. Glue in place one side only.
- D. Put masking tape over the top edge of the R-1 to protect it from sanding the ribs.
- E. Use a 2" x 6" block sander to shape the ribs and trailing edge of the R-3.
- F. Install the 1" balsa hinge block NOW!
- G. Install the 1/16" sheet to the rudder. Trim.
- H. Install the R-2 block "A." Sand flush with sheet.
- I. Turn over and repeat above.

## **UNDER BELLY (U.B.)**

This assembly is designed to be removable for easy access to the hold down bolts. You may choose to make a one piece wing and glue the under belly to the wing which will require access holes to the wing bolts. We advise that you make the U.B. removable.

1. Assemble the U.B.2A, U.B.-2, 3, 4 and 5.
2. Install the wing and bolts. Tighten.
3. Test fit the U.B. assembly to the wing and fuse. Trim the U.B.2A as necessary.

4. Put wax paper between the ends of U.B.2A and fuse bulkheads F-2 and F-4C. Install the assembly with pins.
5. Install the U.B.P. 6's. The two layers of soft 1/16" will make this part easy. Same for the U.B.P. 7's. Use wood glue to install the top U.B.P. 6 & 7's.
6. Remove the U.B. and install the U.B.P.-8's.
7. Install the 1/4" x 1/2" x 2" A/C ply part (for front U.B. hold down) to the F-2 into the opening called for on F-2 template.
8. Install the 1/8" x 1" x 3" A/C ply part to wing with 1/4" overhanging center of wing. (This allows rear U.B. screw attachment.)
9. Install the 1/16" ply inlays at screw head locations. Drill and counter sink for screw heads (1 - #8 x 1-1/2" wood screw and 1 - #8 x 2-1/2").
10. Install assembly using the wood screws. Check for clearance where the U.B.P.-8 nears the wing. You should have a small gap. Install 1/4" x 1/4" stringer to inside of U.B.P.-8 just above its edge to strengthen the area.
11. Suggest you use "Bondo" putty (available auto supply stores and elsewhere) to make a perfect fit of the U.B. to the wing. Lay saran wrap on wing. Use tape to hold flat.
12. Mask the area to avoid a mess. You should have a small spatula to apply and shape your fillet. Do not create a thin edge when shaping.

## FUSELAGE

The fuselage builds onto a simple crutch in the bubble canopy version. The "razor back" version is achieved with the option formed fiberglass part available at a nominal charge.

1. The crutch drawing is supplied on the plans in two parts. Be sure to use a four foot straight edge when taping the two drawings together.
2. Make up the fuselage side parts FS-1 and FS-1A. Use a straight edge along the "Top" edge of these parts to insure an exact straight edge. Note: This edge glues to the crutch and makes the crutch straight. See next step. Use 1/64" ply to double the FS-1. See plans. It must be able to bend to conform to bulkhead curvature.
3. The method of aligning the crutch when installing the FS-1 and 1A side parts is very simple. Make a line down the sides of the crutch on its center. The crutch material is 3/8" x 3/8" so the line should be 3/16" from the top or bottom of the crutch sides. Install pins on this line at each cross piece location.

4. The top of the crutch is the side without the triangle braces. Turn over so these triangle pieces face up. Set the sides (F.S.-1 and 1A) against the pins with the tail ends of the sides even with F-10. Tack glue both sides at F-10 area. Be sure the sides are down against the pins, slowly glue both sides simultaneously to the crutch going forward from F-10. Go Slow!
5. A simple method to keep the crutch from twisting follows.
  - A. Install F-2 and F-8 to crutch. Make up 90° triangles from scrap to insure these bulkheads are glued at 90° to crutch. Very Important.
  - B. Make up two supports from 1/8" x 7" x 12" pieces of light ply. Tack glue to front of F-2 and F-8 up against the fuselage sides.
  - C. The supports align the crutch to your workbench.
  - D. Put the fuselage on the bench in a comfortable place to assemble. Mark the bench where the supports touch. This allows accurate placement when returning the model to the bench.
  - E. In order to check the crutch for alignment, lay an 18" long straight anything across the crutch at F-1 and F-8. Sight these two straights from either end of fuselage. If needed install shims to adjust the support. Recheck alignment.
6. Tacks glue the rest of the bulkheads in place (except F-1 & F-8A). F-9A is now installed between the F-9 & F-10. Sand the exposed edge to angle – see F-9.
7. Install the top center 1/4" x 38" stringer between F-4 and F-9 (do not glue yet). The F-8 should be at 90° to the crutch. Measure the distance between F-8 and F-9 at the crutch level. Glue the stringer to F-8. Measure between the F-8 and F-9. Distance should be the same as the crutch level. Adjust and glue stringer to top F-9. Repeat this through F-4. Install F-1 firewall now. Be positive you have it at 90° to the crutch. Make 90° triangles to assure this. Install F-3 now.

Note: F-8A is installed after retract T.W. is installed to it. You may install F-8A any time before the bottom side stringers are installed. However, before continuing, the tiller arm and 1/8" wire part that holds the wheel must be removed so that the retract can be retracted up into the fuselage because the rest of the lower fuse parts are installed over the retract. Then the T.W. door material is laminated (3 layers of 1/64" ply with a thin layer of white glue applied to both sides of center layer) and then taped to the door area of the fuse. This creates curve shaped doors. Then door template is then placed on the curved door material and the doors are then cut out. Neat, eh?

8. The F-123 part when installed to top of F-1, F-2 and F-3 might require trimming of the notches to allow the F-2 & F-3 to remain at 90° to crutch. Install the two F-

123-A and F-123-B parts now, to the first notches above crutch in bulkheads F-1, F-2 and F-3.

9. Install the two stringers just below the crutch. Use clothespins to clamp the bottom of FS-1 and 1 fuselage sides to the stringers. Do both sides at the same time to avoid distortion of crutch. Check crutch alignment again. If O.K., glue the sides to the stringers.

**STOP HERE:** Because of the interesting features presented in this design you must take time here and now to decide on which features you want to incorporate into your project. We hope you decide on all of them. The following will describe the methods and reasons for prescribed steps for the several optional features.

10. After the controls are all installed along with the doors, install all top stringers. Keep checking crutch alignment as you go and install to both sides at same time to help avoid distortion. Put all stringer extension splices to rear between F7 and F8. The 48" pieces install forward area.

Latent Note: If you do not install the "Air Vane" part when doing the intercooler doors, you can remove the doors (which helps avoid damage) until later in the program. Make a screwdriver access hole directly above the pivot/screw (in the FS-4A plank) for reinstallation later on.

11. Install balance bottom stringers. Note: These stringers should extend forward from F-5 by 2-1/8" (they are trimmed later on).
12. Install FS-3A plank. Be sure it fits flush with back of F-10.
13. Install a 1/64" x 2" x 1" splice doubler to FS-3A before installing the FS-3. Be sure the 1/64<sup>th</sup> splice doubler wood grain runs forward (not up and down). Same for all splices.
14. Install intercooler doors now! If you are building the razor back you may elect to leave a hole in the top plank to facilitate "door" pivot screw removal. Removing the door until construction is complete is a very desirable feature. The 1/32" ply part "air vane" can be installed after final door installation.
15. Install the rest of the top planks FS-4, 4A and FS-5.
16. The F.S.-2 installs next. Because there is no stringer to glue to, F.S.-2 must be edge glued to the bottom edge of F-1. Be sure it fits to the wing saddle shape of F.S.-1. Suggest you tape the F.S.-2 part in place and then glue it.
17. Install the F.S.-2A now being sure it fits flush to back of F-9. Trim at splice if necessary. Install F.S.-2B. It must fit curvature of the airfoil shape of F.S.-1. Do not fit any of the F.S. parts flush to F-1. They all will hang over a bit. Sand flush to F-1 after installation.

Install wing saddle doublers NOW. (Suggest you put many holes into the wing saddle doublers in order to more easily apply thin C.A. to the areas.)

18. Install wing hold down 1/2" x 1" x 6" hardwood blocks.
19. Locate the F-4C lower bulkhead and the F-4D part, which locates the F-4C part to its proper location and angle. Install.
20. Install the F.S.-2B bottom planks and the balsa blocks F-9 B & c to F9A. Shape.

Note: Put the T.W. door part in exact position. Draw a line around the doors. Cut away the wood to this line. Now your T.W. is accessible.

21. Make up the 1/32" ply wing fillet part.
22. Install the wing to the fuse being sure to measure from a point on the wing back to the F-10. Drill through the hole in the wing (1/4" x 20" x 2" bolt hole) into the 1/2" x 1" x 6". Hold down block. Remove wing and check to see if the dimple is on center of the block. If so, change drill bit to a 13/64" bit then finish drilling through. Now tap a 1/4" x 20" thread through the blocks.
23. Make up many triangle braces from 1/8" balsa that is installed to top of 1/32" ply fillet part and against fuse side. These act to hold the 1/32" ply down against the wing.
24. Mix up a batch of micro balloons and polyester resin putty. Fill fillet area. Sand to shape.
25. If the front of the wing appears to be a bit loose, add a piece of 1/64" ply to the bottom of the tongues to shim the wing upwards.
26. Now that the wing is installed, you can install the horizontal stab, as you need the wing for stab alignment. The vertical stab follows. See pictures on plans for shape of area between fin and stab. Use soft blocks.

When the Supercharger compresses the air, the air gets too hot for proper use by the engine, thus a method to cool this air is used. Compare the hot compressed air to the water in your car engine. As you know, the hot water is fed through your radiator in which cool air is pulled around the many tubes that hot water circulates through. Now, imagine the hot air being drawn and pushed through these same many tubes with cool air being forced around these same tubes. This is what intercoolers are, radiators that cool hot air – not water.

If you want to install moving intercooler doors (neat idea), it is a very simple matter because all of the figuring has been done. All you have to do is cut out the various wood parts per the several templates. Assemble as shown and install with one pivot screw per door. Flex Cables Sullivan #508 (2 regular) are hooked up to the throttle servo or an aux channel for movement.

Even the routing of the cable housing is plotted for you. YOU MUST DO THIS NOW!!!

Important Note: The reason we recommend and show the use of Nyrod type controls is because they are very easy to route through the fuselage. They are also very reliable and simple to hook up. Depending on whether you choose the removable cockpit floor and moveable intercooler doors determines the need to route all of these controls (8 so far) as shown. If you are on top of such matters, you of course can do your own thing. For those of you who have better things to do than engineer a new “mouse trap” be assured that all control systems shown are simple to install and very reliable. Amen!

- A. Retracts – Main. We offer custom struts for the P-47 and economical retractors for this model (see [www.meister-scale.com](http://www.meister-scale.com) or our latest catalog for info). The installation is made easy due to the prearranged mounting platform installation. If this is your first time at retracts please do not hesitate to go for it. They are very easy on this model.

If you opt not to install retracts you can install gear grooved blocks just like in your smaller models. Use a main block and then a shorter one just behind the leg (about 5”) to support the backward movement of the leg. Solder the support to the leg using small diameter copper wire. (About 4” down the leg from the wing.)

- B. Tail Wheel Retracting. It is a very simple job to make up your own retracting T.W. using the supplied plans and templates. Most heating and air conditioning contractors will have the .010 galvanized sheet metal you will need. The square brass tube is K & S which all hobby stores have. You can make this retract in less than three hours. Your alternative is to purchase a Robart Manufacturing or similar retract which will fit nicely in the fuse. This item is in stock and we can ship on receipt of your order either by mail or by phone with your charge card. In any event, you need it now in order to continue with the fuselage.

Note: The T.W. location shown on the side view on plans is in the exact scale location.

Very Important: The retract T.W. must be installed to the F8A bulkhead before the bulkhead is installed to the crutch.

- C. Intercooler Air Exit Doors. For your enlightenment the plans illustrate several drawings showings some of the many fascinating inside systems of the P-47.

## **FLYING**

The P-47 has the same “Fun Scale” characteristics as its predecessors. Very slow take off and landing capabilities so do not use much throttle on first take offs, if you want realism.

The P-47 is very acrobatic if set up for it, so help yourself.

## **CONTROL THROW SET UP**

1. Ailerons 1” up and 1”down.
2. Elevators 1” up and 1” down.
3. Rudder 2” each way.
4. Throttle must be set to a low idle to allow the model to fly slowly enough to land.  
Note: The above can be changed to individual taste after initial flights.

NOTE: .010 GALVANIZED SHEETMETAL IS FOUND AT HEATING & A/C BUSINESS PLACES

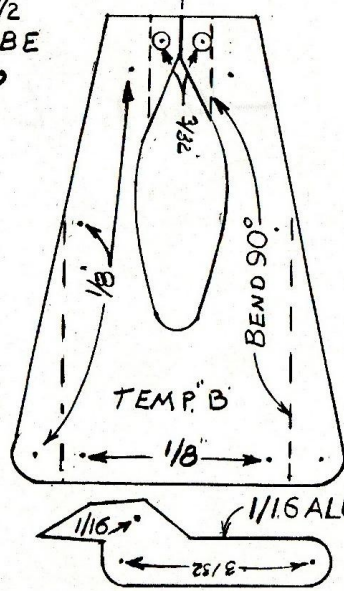
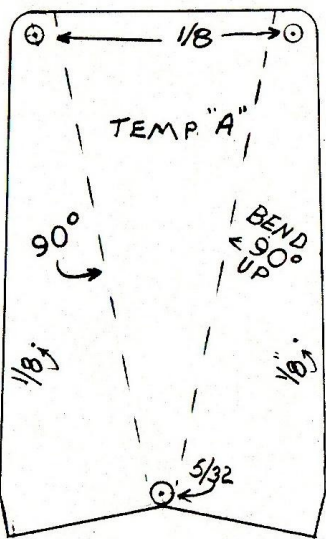
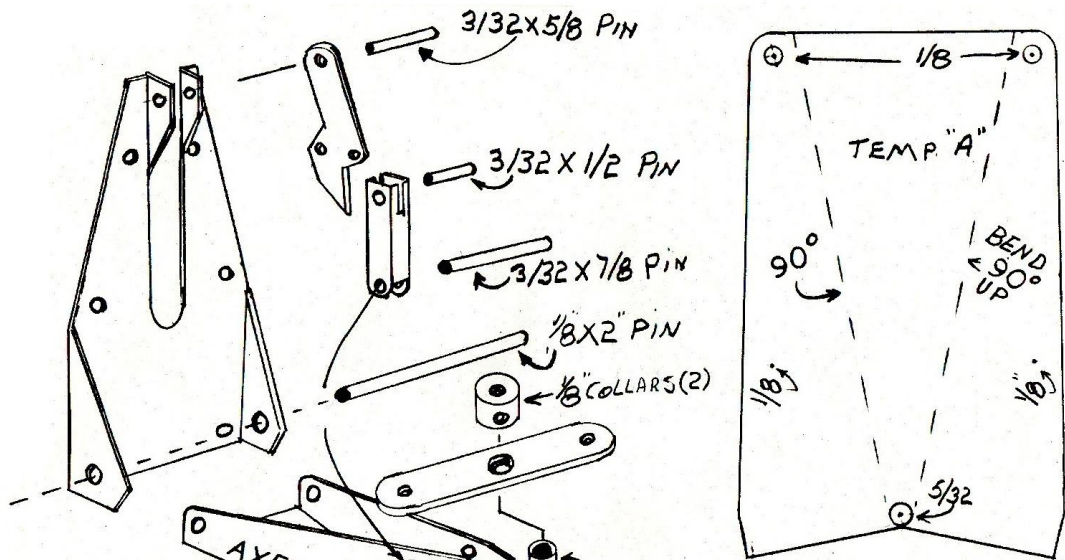

**MEISTER SCALE  
UNIVERSAL RETRACT  
TAIL WHEEL PLANS**

1. TAPE TEMP'S "A" & "B" TO .010 SHTMTL
2. PUNCH MARK ALL HOLE LOCATIONS
3. MARK THE FOLD LINES
4. DRILL ALL HOLES
5. FOLD "A" & "B".
6. ASSEMBLE ALL PARTS & SOLDER ALL PINS, COLLAR TO TILLER & 1/8 TUBE

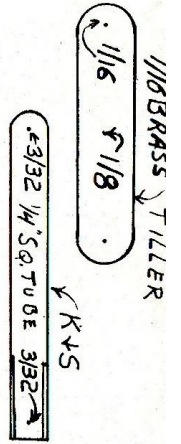
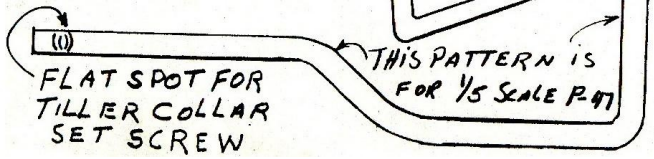

1/16 BRASS TILLER

K+S

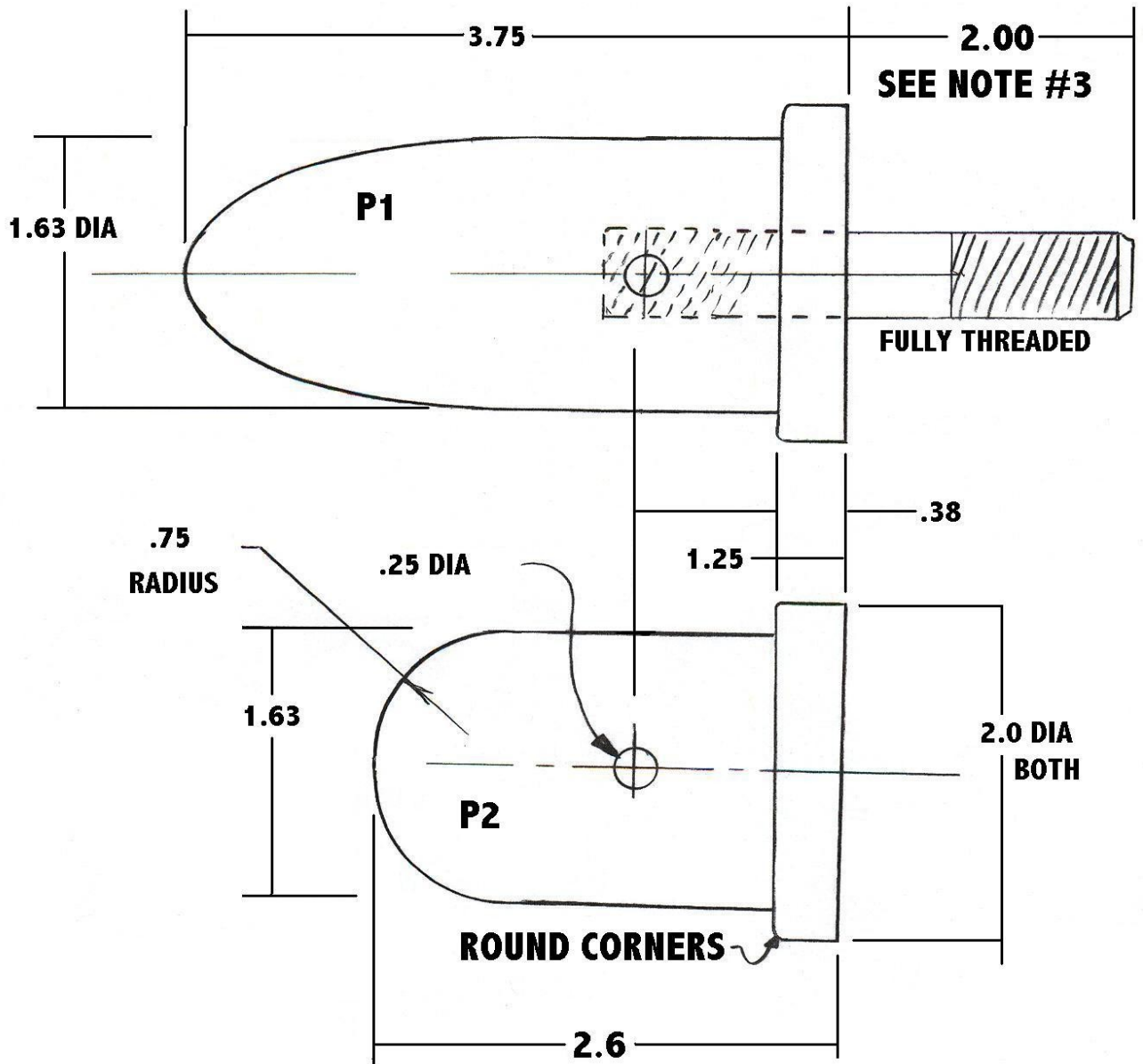

## ALUMINUM SPINNER HUBS

**P1/P2 P-47**  
**P2 F4U**

### NOTE:

1. STUDS REQ'D ON BOTH SIDES
2. ALUMINUM
3. THREAD SIZE: 3/8-24  
FOR QUADRA 65, 75 & 100

**1/5 SCALE**

**P-47 RAZORBACK  
CANOPY FRAME**

**1/8 A/C PLY  
6X8**

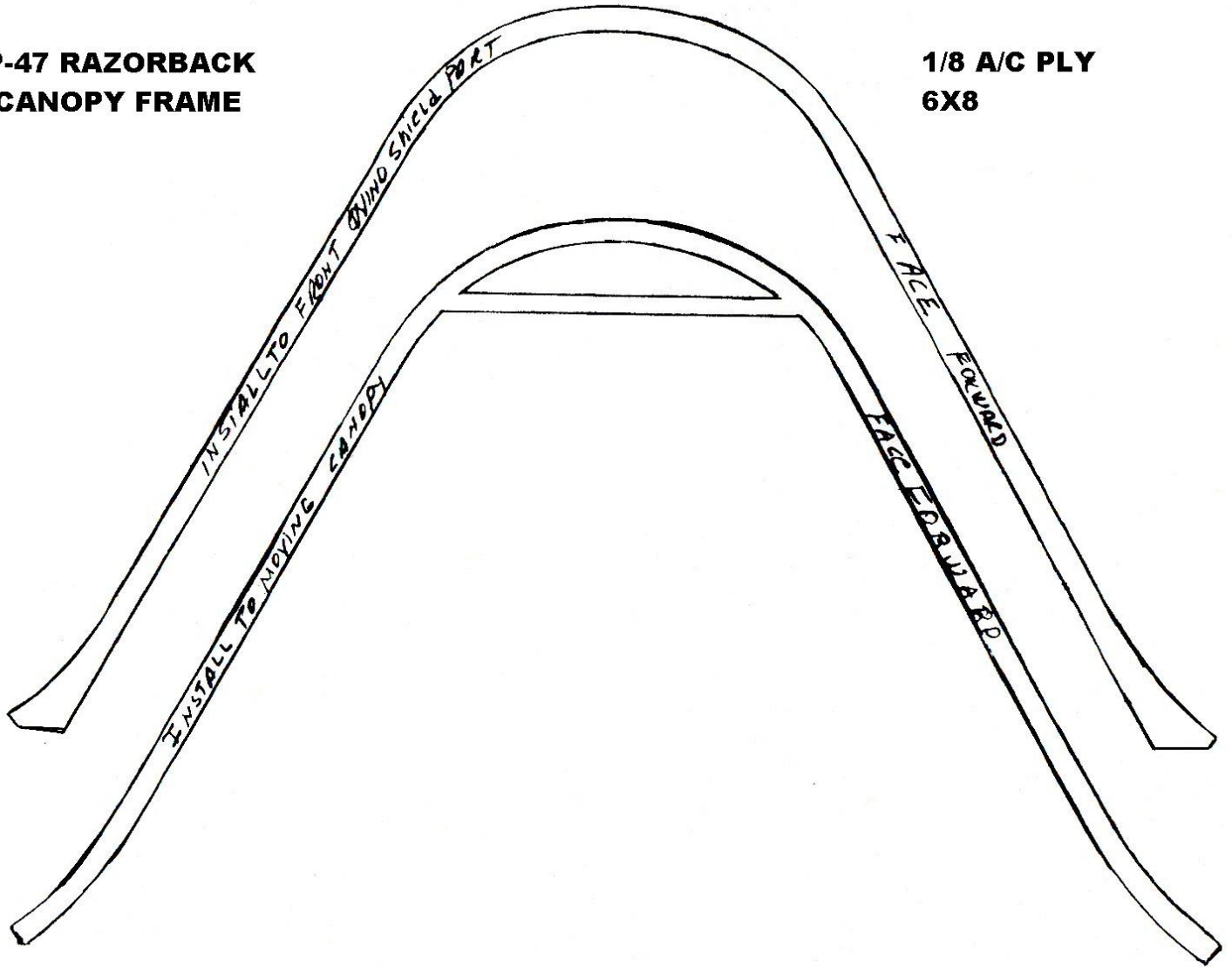

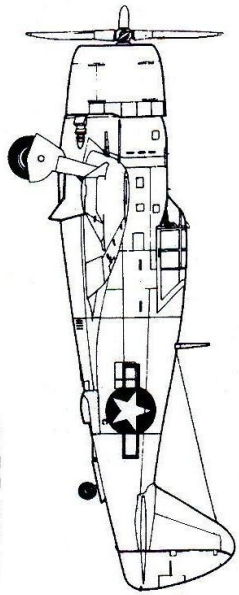

Republic P-47D  
"THUNDERBOLT"

**SLIDING CANOPY DETAIL**

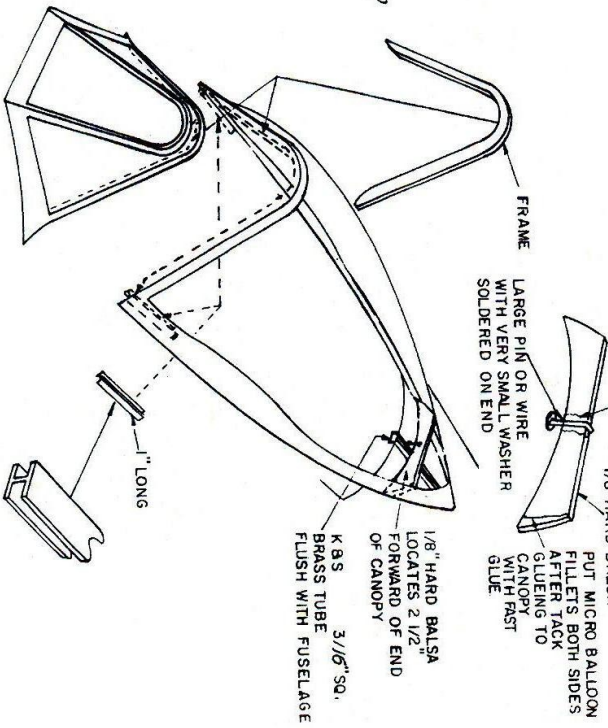
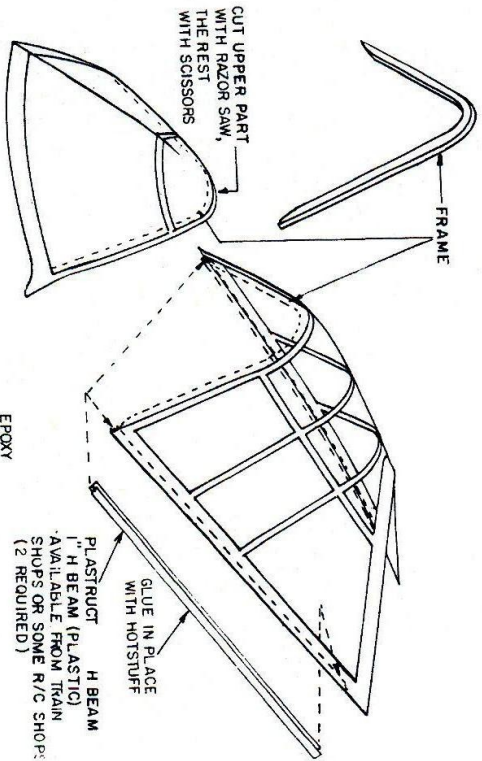
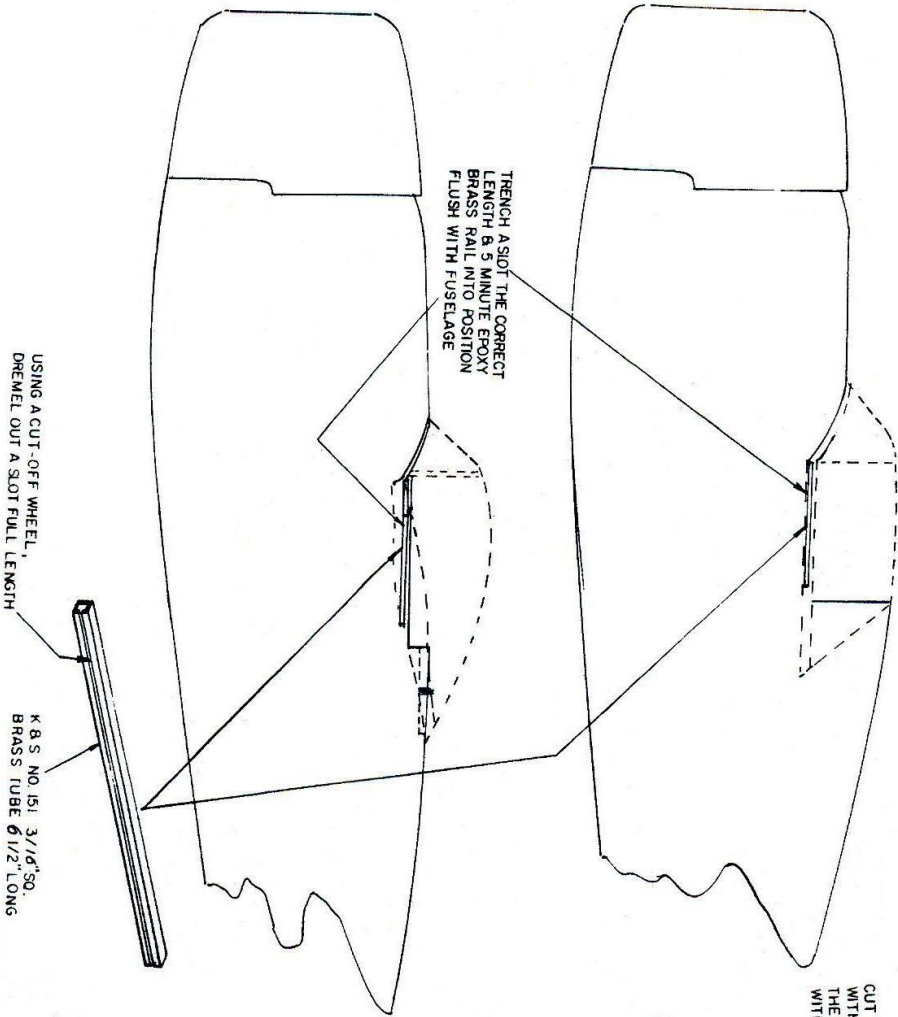

**MEISTER SCALE FUSE SIDE DOOR**

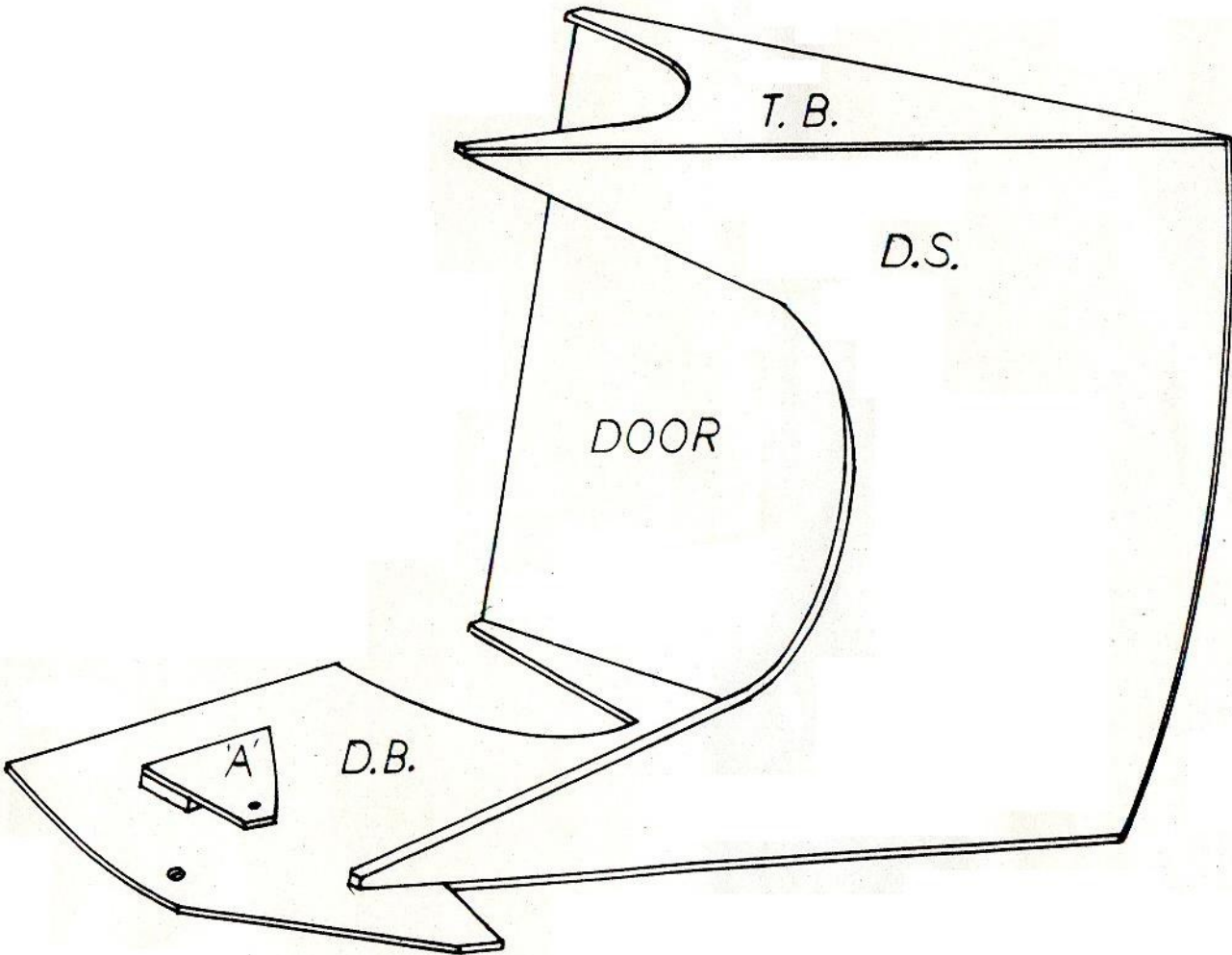

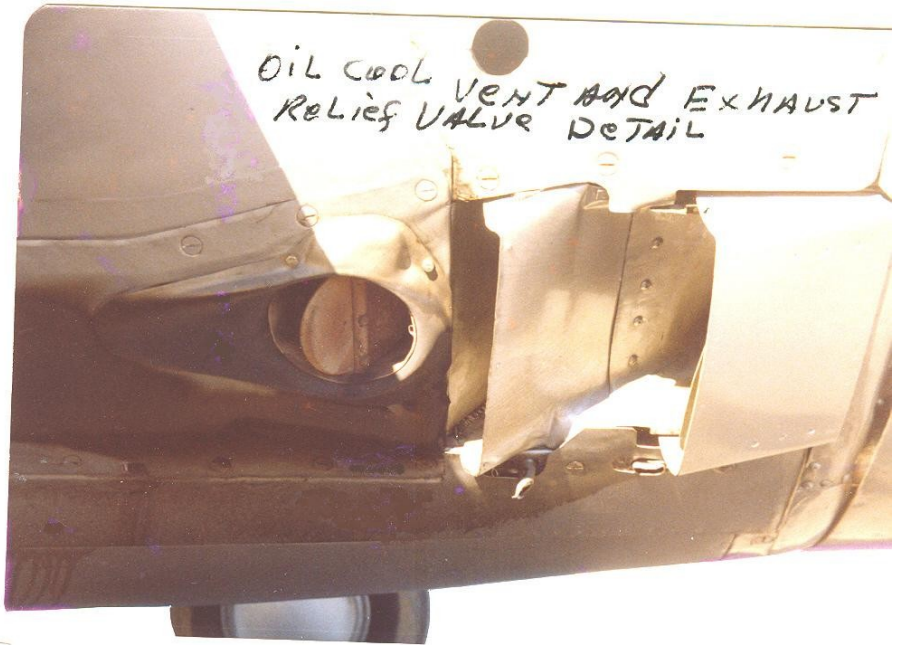

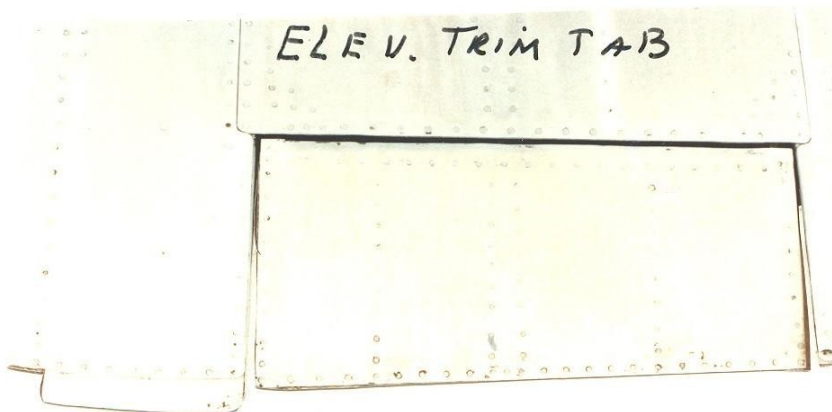
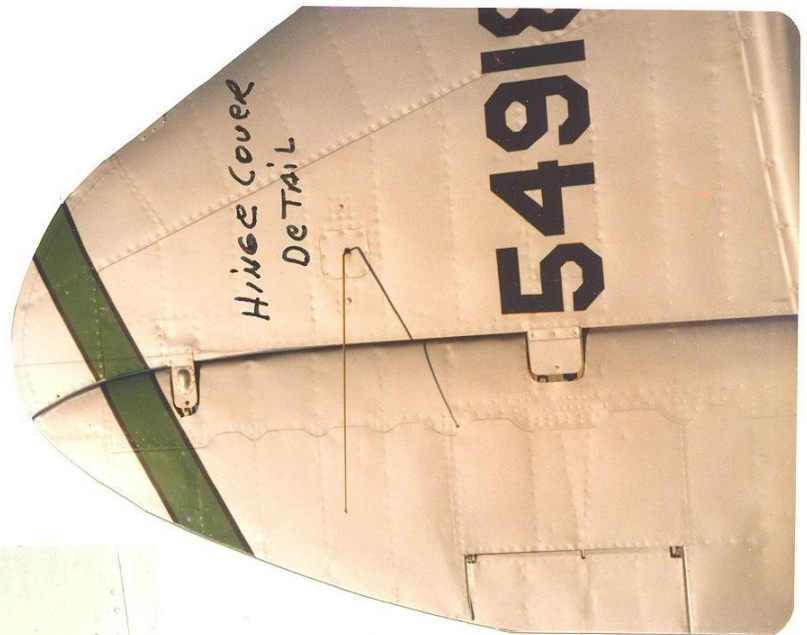
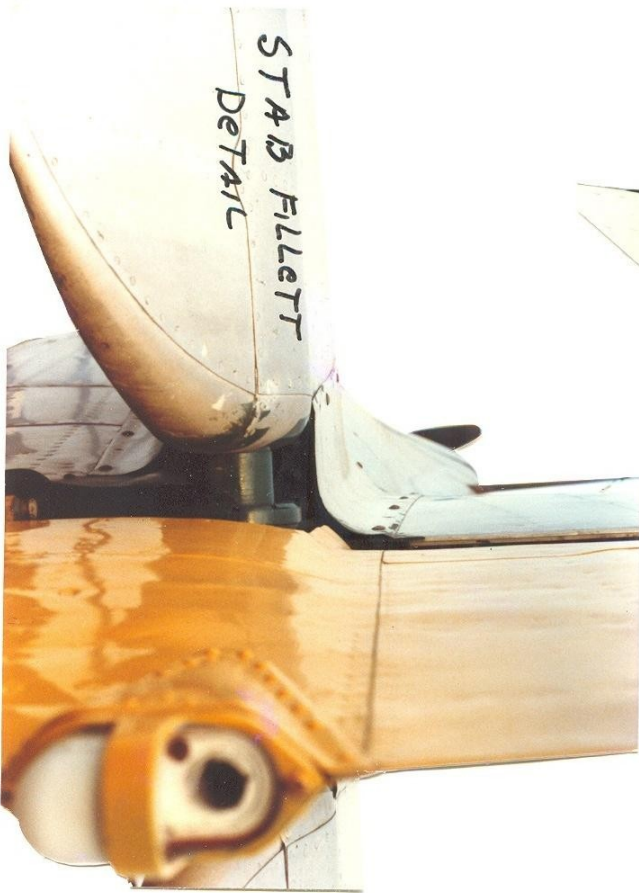
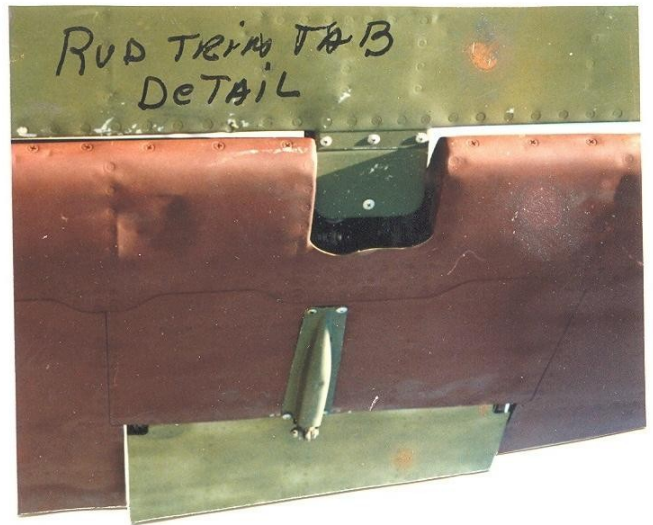
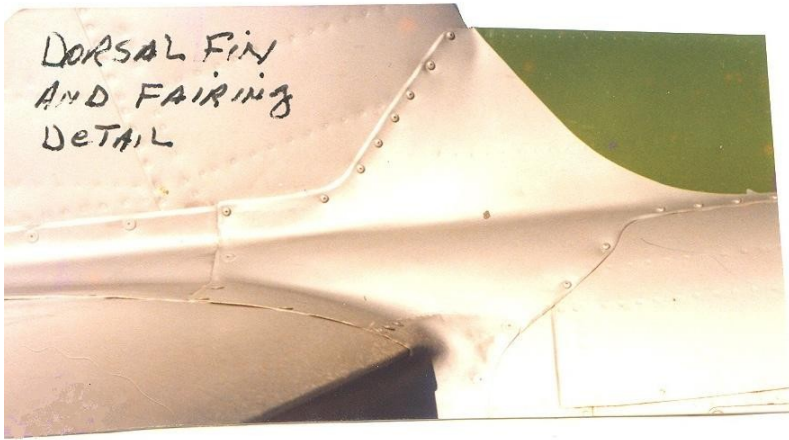

**MEISTER SCALE P-47 DETAIL AID**  
**10-10-94**



UNDER BELLY DETAIL

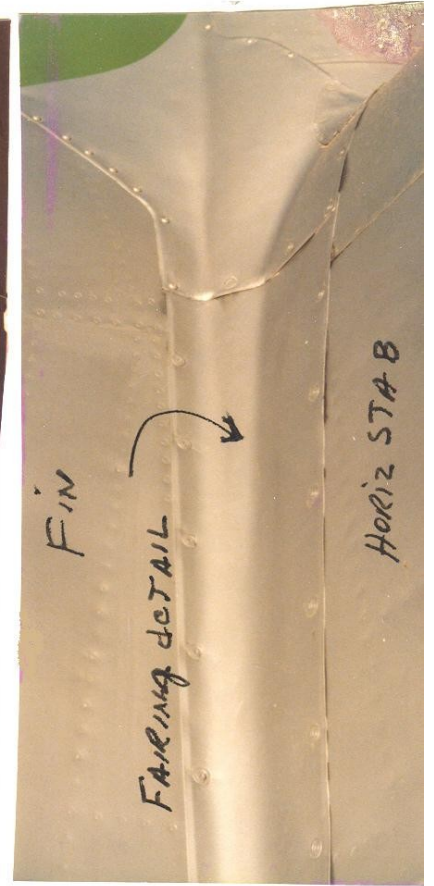

Wing L.F. FAIRING DETAIL



# Republic P-47D "THUNDERBOLT"

## SPECIFICATIONS

	P-47D	P-47N
Span	40' 9"	42' 7"
Length	36' 1"	
Wing Area	300 sq. ft.	322 sq. ft.
Weights:		
Empty	10,000 lbs.	11,000 lbs.
Loaded	19,400 lbs.	20,700 lbs.
Max. Speed	429 m.p.h. at 30,000 ft.	467 m.p.h. at 32,000 ft.
Ceiling	42,000 ft.	43,000 ft.

	P-47D	P-47N
Range	1,700 miles	2,200 miles
Power	R-2800-59 2,300 h.p.	R-2800-57/75/77 2,800 h.p.
Armament	8 - .50 Cal. M.G. 2 - 1000 lb. bombs 1 - 500 lb. - 2 1000 lb.	8 - .50 Cal. M.G. 3 - 1000 lb. or 10 - 5 in. rockets
Total Built All Types	15,660	

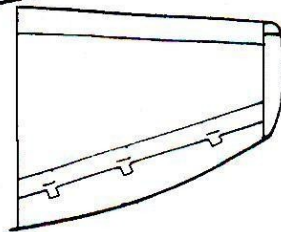
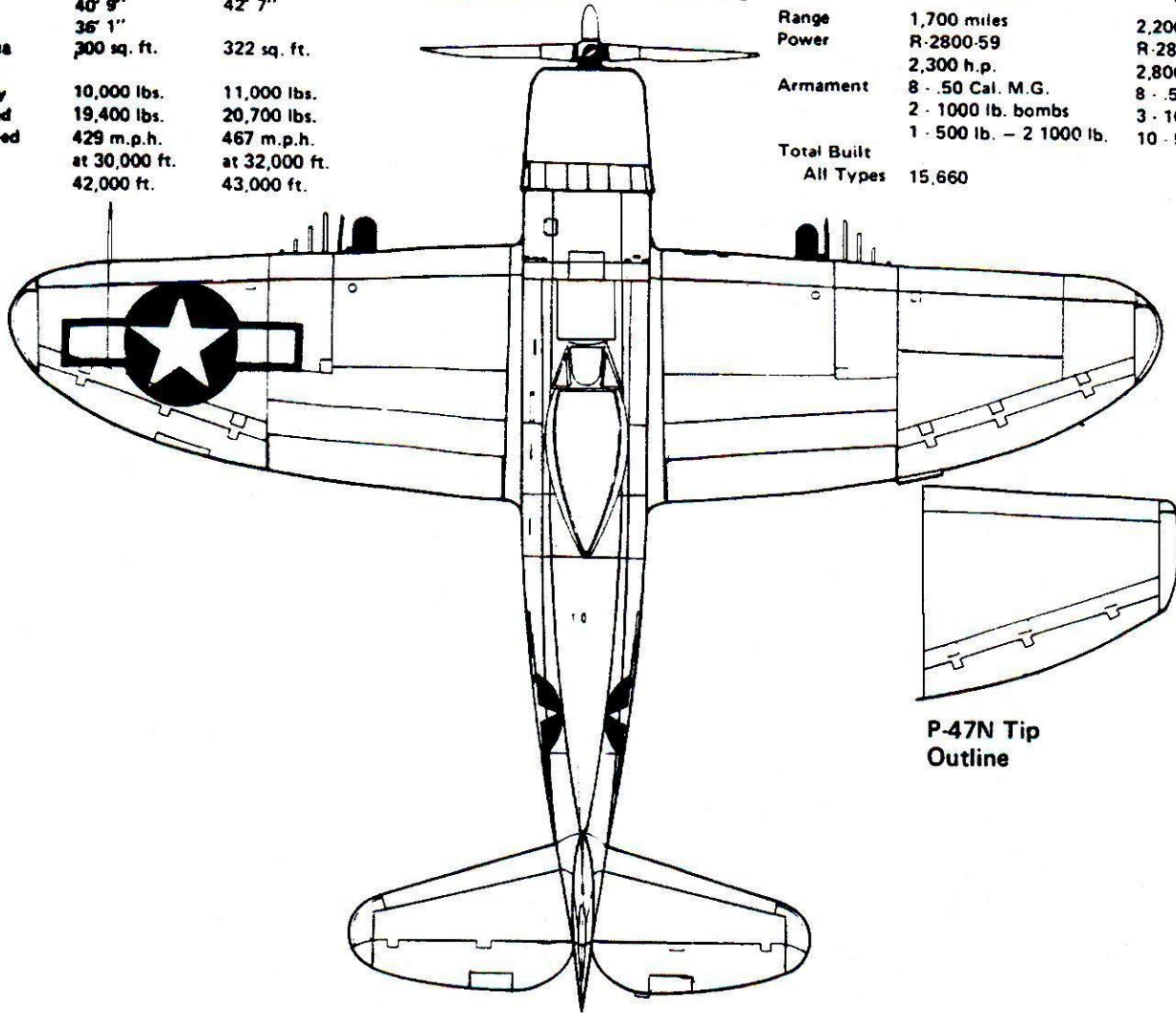

P-47N Tip  
Outline

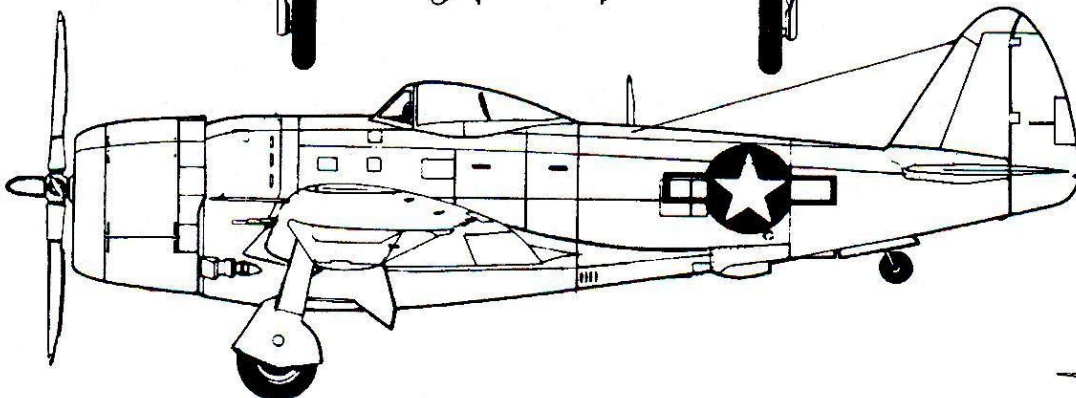
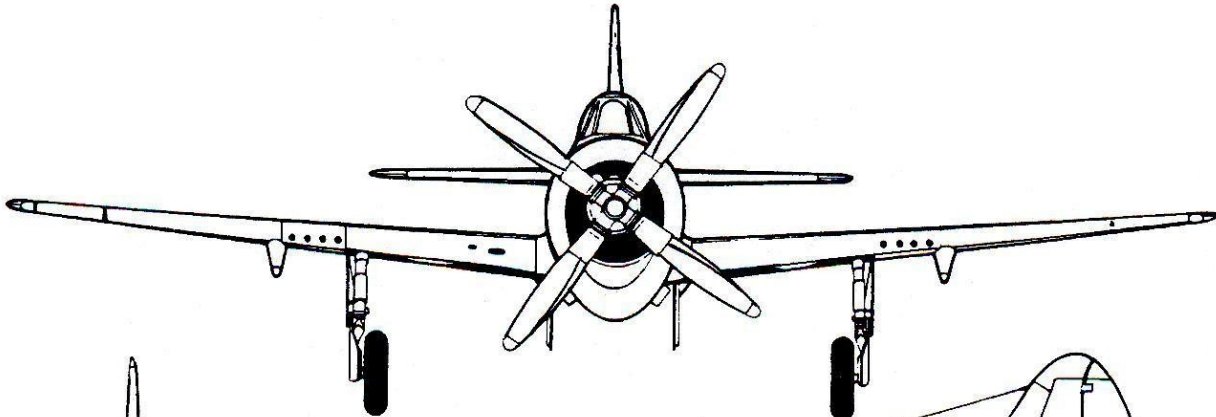

# Republic P-47D "THUNDERBOLT"

## SPECIFICATIONS

	P-47D	P-47N
Span	40' 9"	42' 7"
Length	36' 1"	
Wing Area	300 sq. ft.	322 sq. ft.
Weights:		
Empty	10,000 lbs.	11,000 lbs.
Loaded	19,400 lbs.	20,700 lbs.
Max. Speed	429 m.p.h. at 30,000 ft.	467 m.p.h. at 32,000 ft.
Ceiling	42,000 ft.	43,000 ft.

	P-47D	P-47N
Range	1,700 miles	2,200 miles
Power	R-2800-59 2,300 h.p.	R-2800-57/75/77 2,800 h.p.
Armament	8 - .50 Cal. M.G. 2 - 1000 lb. bombs 1 - 500 lb. - 2 1000 lb.	8 - .50 Cal. M.G. 3 - 1000 lb. or 10 - 5 in. rockets
Total Built All Types	15,660	

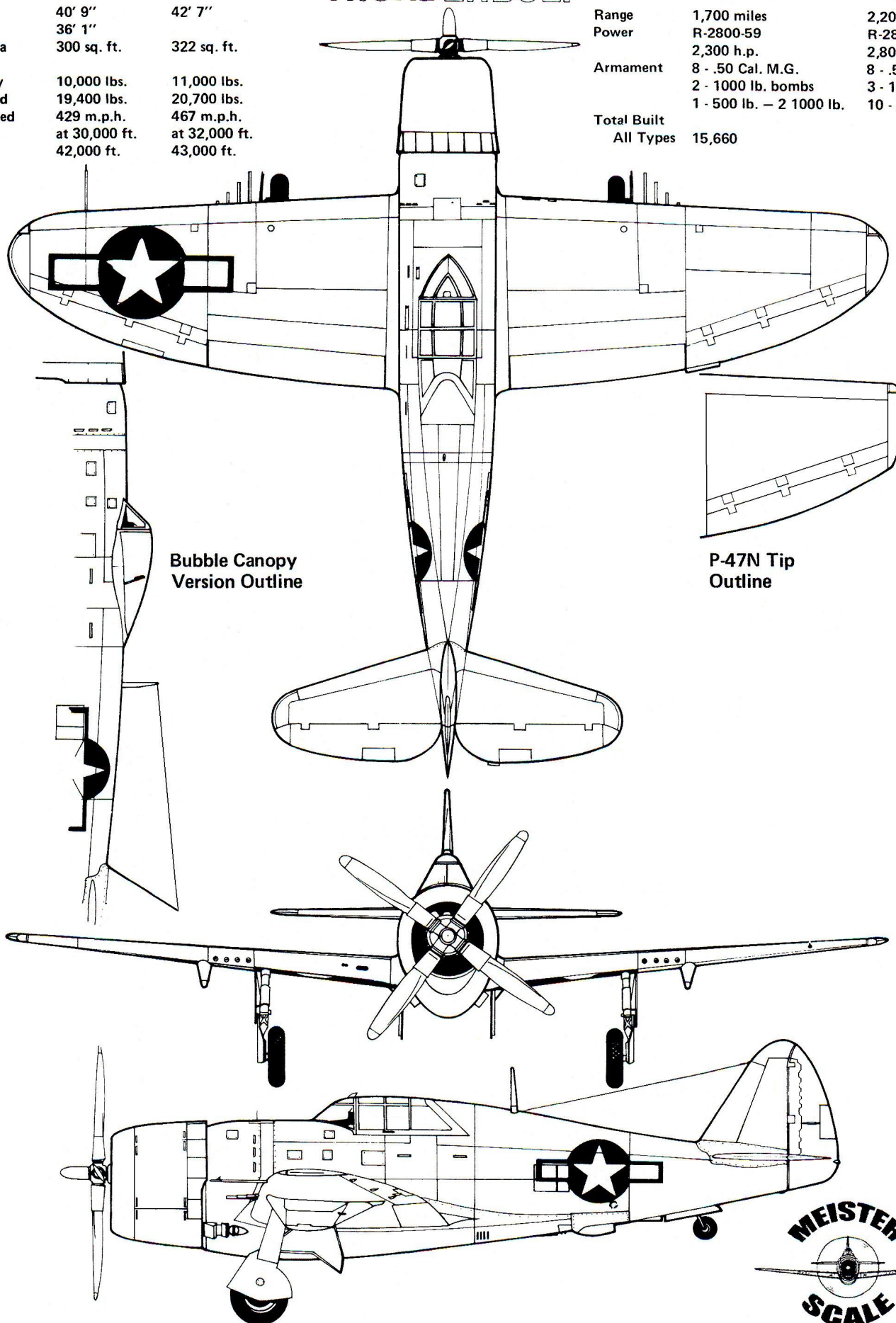

### FUSE LIST (BALSA)

1 -	1/16" x 3" x 36"	Hard	HRS, HRP, ARMOR PLATE
4 -	1/16" x 3" x 36"	Soft	UBP Planks 6, 7, 8
10 -	1/8" x 3" x 36"	Med	All non-ply bulkheads F9A, F9B, RB1, FS Parts, UB2A, BF4, HR
4 -	1/8" x 4" x 36"		F8, FS-2C, FS-5, FS-5A
30 -	1/4" x 3/8" x 36"	Med	Stringers
1 -	1/4" x 3" x 36"	Med	F123, F123A & B
6 -	3/8" x 3/8" x 36"	Med	Crutch
1 -	1/2" x 3" x 36"	Med	F9C, F9D

### FUSE LIST (HARDWOOD)

Note: All parts marked 1/8 ply may be made of light ply.

3 -	1/64" x 6" x 12"	Ply	TW Doors & Seat Back
1 -	1/32" x 6" x 12"	AC	Door base, Air Vein, Top Brace
1 -	1/8" x 12" x 48"	Ply	F2, F3, F4, F4D, F8A & B, F10, DS-Dash, Seat Base Support & Cockpit Floor
1 -	1/4" x 12" x 36"	AC	F1 & Wing Tongue Doubler, Cowl Plate
1 -	1/2" x 1" x 24"	Bass	Wing Hold Down Blocks
1 -	1/2" x 1-9/16" x 24"	Pine	Cowl Spacer Blocks

### HORIZONTAL STAB

3 -	1/8" x 3" x 36"	Hard	S-1 Thru 6, S-8, 9 & 10 E-1 Thru 5, E-8 & Stab Sheet
1 -	3/8" x 1/2" x 18"	Med	Hinge Block
1 -	3/8" x 3/4" x 36"	Med	Stab Leading Edge

### ELEVATORS

1 -	1/16" x 4" x 36"	Hard	E-9
1 -	1/2" x 3/4" x 36"	Med	Hinge Blocks
1 -	1/2" x 3" x 6"	Med	E-6
1 -	1" x 1/2" x 6"	Hard	E-10

## WING Balsa

4 -	1/16" x 4" x 36"	Hard	Ailerons
3 -	3/32" x 2" x 24"	Med	"H" and FT-2
4 -	3/32" x 4" x 36"	Hard	AIL Webbing
2 -	1/8" x 3/8" x 36"	Hard	Spar Extensions
10 -	1/8" x 3" x 36"		Sheet "E", FB1 & 2 FX, FH-2, F-G, F-T and GT Ribs W-1 Thru W-4, W-8 Thru W-14 LE-2 Flap & Ailerons-Ribs
2 -	1/8" x 3" x 48"		Sheet "B"
12 -	1/8" x 4" x 48"		Sheet "A", "C", & "D"
2 -	1/4" x 1/4" x 36"	Med	Top of Ribs W-2 Thru W-8
2 -	1/4" x 3/8" x 36"	Med	Bottom Spar Extensions
6 -	1/4" x 1/2" x 36"	Med	Secondary Spars
7 -	3/8" x 3/4" x 36"	Med	Main Spars AH-1 & AH-2
2 -	1/2" x 1/2" x 36"	Med	FH-1
2 -	1/2" x 1-1/2" x 48"	Med	LE-1
2 -	1" x 1-1/2" x 36"	Soft	FP-1
1 -	1-1/2" x 3" x 18"	Soft	Tip
1 -	1/32" x 6" x 24"	Ply	Flap Top Sheet Part FT, "H" & Wing Fillets
1 -	1/16" x 12" x 24"		Ply Gear Doors
1 -	1/8" x 6" x 24"		Lite Ply W-5 & W-7
1 -	1/8"	AC Ply	Wing Bolt Plate, W-5A, W-7A, Servo Rails
1 -	1/4" x 6" x 24"	AC Ply	Wing Tongue Gear Plate & Flap Servo Rails
4 -	1/2" x 1/2" x 8"	Pine	Gear Plate Reinforcement
1 -	3/4" x 2" x 36"	Bass Wooder Stika	Spar Brace & Winghold Down Blocks