

Hawker Hurricane Mk II Construction Manual



Scale: ¼ exactly

Span: 122 inches

Wing area: 2477 square inches

Fuselage length: 8 feet.

Weight: 48 lbs (electric version) 51 lbs (gas version)

Designed by David P Andersen 2014.

Free plans on www.mnbigbirds.com

Prototypes by Roy Maynard, Jeff Quesenberry, Chris O'Connor, Barry Vogel, Chuck Hamilton and Richard Rice (New Zealand). They also contributed ideas into the design. Thanks, guys.

Table of Contents:

Parts List	Page 2	Rudder Construction	Page 55
Fuselage	Page 6	One-piece Stab	Page 60
Fuselage--Gas Motor	Page 27	Removable Stab	Page 65
Radiator	Page 29	Wing Center Section	Page 72
Oil Cooler Intake	Page 36	Outer Wing Panel	Page 82
Oil Cooler Installation	Page 40	Surface Details	Page 93
Retract Specifications	Page 41	Control Surface Throws	Page 95
Flap Assembly	Page 42	References	Page 96
Elevator Assembly	Page 46	Walk Around Photos	Page 99
Fin Construction	Page 51		

Parts List

Balsa sheets:

14—1/16 x 3 x 36	Fin & stab base, stab sheeting, fin sheeting
42—3/32 x 3 x 36	Fuselage sheeting, <u>4-6 lb contest grade.</u>
3—3/32 x 4 x 24	Flap cores
5—1/8 x 3 x 36	Fin & stab ribs, rudder base, trim tabs
20—1/8 x 3 x 48	Outer wing panel sheeting
38—1/8 x 4 x 36	Sheer webs, inner panel sheeting, outer wing ribs
2—1/4 x 3 x 36	Stab support, stab reinforcement
1—3/8 x 3 x 36	Fin LE, elev trim tabs, stab & elev tips
2--1/2 x 4 x 36	Radiator bottom & sides, F23, fin fairing
2—1 x 3 x 12	Rudder top, elev horn support
1—3/4 x 3 x 36	Inner panel LE
2—3/4 x 3 x 48	Outer panel LE, gear door fairings

Balsa Blocks:

3—2 x 4 x 12	Wing tips, radiator front (if balsa radiator is elected)
1—2 x 4 x 2	Oil cooler intake (if carved balsa scoop is elected)

Balsa sticks:

7—1/8 x 1/4 x 36	Elevator cross braces, aileron spars, elev spar
62—1/4 sq x 36	Fuse stringers, elevator balance
7—1/4 x 1/2 x 36	Stab spar, flap hinge support
2—1/4 x 1 x 36	Stab TE
5—1/2 sq x 36	Spars
5—1/2 x 3/4 x 48	Spars
4—1/2 x 3/4 x 36	Elev LE, aileron hinge supports
2—3/8 x 1/2 x 36	Stab LE
1—1/2 x 1/2	Triangular Rib gussets.

Hardwood sticks:

1—1/4 x 1/2 x 6	Doubler
1—3/4 sq x 36	Lower center section main spar
1—1/2 x 3/4 x 36	Lower center section rear spar
1—1/4 birch dowel	Stab alignment, wing LE support, wing alignment

Poplar Light Plywood:

6—1/8 x 12 x 48	Formers, stab ribs, wing ribs, servo support, washout sticks
-----------------	--

Birch Plywood:

2—1/64 x 12 x 24	Flaps, wing filet
------------------	-------------------

- 1—1/32 x 12 x 24 Lower wing filet
- 1—1/16 x 8 x 12 Radiator base, antenna base
- 1—1/8 x 12 x 24 Battery box floor, stab ribs, F3, servo tray
- 1—3/16 x 8 x 8 F3 electric motor firewall
- 1—1/8 x 12 x 48 Ribs 8 & 9 (2 each)
- 1—3/8 x 6 x 12 Wing bolt support, upper door supports

Estimated total wood cost: \$445 list as of May 2014 from Balsa USA

Cut wooden parts are available from
Leon Cole, Belair Kits, www.belairkits.com Tel: +44 (0)1362 668658 (England)

Other hardware:

- 1--Hidden Latch System. <http://www.details4scale.com>.
- Gun sight, seat, control stick, harness, instrument panel, pilot, etc.:
<http://www.iflytailies.com>
- 1 pair—Central Hobbies 1/4" x 38" Carbon Rods/Titanium Ends CHMPRS38T4,
http://www.centralhobbies.com/control_linkage/pushrod2.htm
- 2—7/8" x 30" aluminum wing tubes with sleeves (Zirolì Plans)
- 1-- 5/8" x 18" aluminum tube w/phenolic socket (TnT Landing Gear). Removable stab only.
- 23—Robart Super Hinge Points and Pockets
- 2 – K&S 9/32 x .014 Stock #107 aluminum tube (Robart hinge extensions)
- 1—5/32 x 36 music wire Elevator horn
- 1--1/16 x 3 x 6 Aluminum Rudder horn
- 2—SIG SA1025/32" Nose wheel steering arm--Elevator horns
- 9—4-40 threaded music wire (elevator and flap pushrods)
- 2—4-40 Ball links (aileron servos)
- 10—4-40 Kwik Link clevises (flaps, tailwheel)

Molded parts available from Micko Aircraft and Accessories (www.mnbigbirds.com):



- Canopy
- Cowl chin
- Fiberglass radiator
- Fiberglass oil cooler intake
- Exhaust manifold (vacuum formed)

Alternatively, Nick Zirolì ZIR:SPIT7 Scale Exhaust Manifold (cast resin)



ScaleRcParts (Kirk Schneider) 3D printed oil cooler (1 1/4 oz)
Contact: ScaleRcParts.com



3D printed cannon barrels and shrouds are available from ScaleRcParts.com.



3D printed Merlin hollow exhaust manifolds and cowl blisters available from ScaleRcParts.com. Landing lights not shown.

6—1/4 x 20 DU-BRO nylon bolts Wings bolts, radiator

8 pkgs (80 feet) —1/16” x 120” Line O Tape pinstripe tapes masking tape (simulated stringers)

Landing Gear:

1 set Shindin Andersen Hurricane electric or air retracts and struts (<http://www.shindinmachine.com>)

OR...

1 set John Mesoella Andersen Hawker Hurricane electric (power box required) or air quarter-scale retracts and tailwheel strut



Matrix Machine Tool

100 Boxart St.

Rochester NY 14612

matrixmt@earthlink.net



Alternatively, ROBERT Giant Scale Fixed Tail Wheel Assy No. 657 (non-scale)

Alternatively, Mick Reeves quarter-scale Hawker Hurricane retracts

<http://www.mickreevesmodels.co.uk/~mickreev/spits/p4spit.htm>

For other retracts, see Quarter scale Hurricane retracts specs.doc

1 pair Mick Reeves 6” Hurricane wheels

<http://www.mickreevesmodels.co.uk/~mickreev/spits/p4spit.htm>

Alternatively, 1 pair ROBERT 6” tires and A4 Large 4 spoke Spitfires hubs

<http://www.robart.com/store/wheels/aluminum-wheels-4-6>

1--DU-BRO 2 1/2” smooth surface or ROBERT 2 1/4” treaded tailwheel

1 pkg Tom Cook 1/16” air line tubing clamps

(<http://www.jetmodelproducts.com/landing.htm>)

1 pkg ROBERT or Tom Cook 1/16” air line tubing

1--.025” x 8 x 18 aluminum sheet. Gear doors

2—10-24 stop nuts Axle ends

2—8-32 x 1/2” SH machine screws End strut set screws

- 2—1/4" DU-BRO wheel collars Axle spacing
- 4--#6 1/2" wood screws Door guide
- 2—3/4" diameter strut collars (Sierra Giant Scale, <http://www.sierragiant.com>)
- 4—6-32 x 1/2" FH machine screws Sierra strut collars.

1—Cockpit kit, Dynamic Balsa (Brian), dbalsa.com

Sound System:

Model Sounds with two 4-inch speakers
<http://www.modelsoundsinc.com>
 Model Sounds
 Suite 712, 31 McEwen Avenue
 Ottawa, Ontario, Canada, K2B 5K6

Alternatively,

<http://www.aerosoundrc.com/> or
http://www.benedini.de/Home_E/Products_E/products_e.html

Power:

Hacker 150 or 200 electric motor or Turnigy RotoMax 100 electric from Hobby King

Power supply for electric motor: #9107000345-0/63509

Turnigy 9 Channel Independent Power Supply

Eight Thunder Power 7C 5000 mAh Lipo batteries

JETI SPIN 300 Pro Opto electronic speed control with one

EverCool EC 5015 5 volt DC, 4500 rpm, ball-bearing cooling fan

Or...

Desert Aircraft DA 100 twin cylinder inline gas engine

Or..

3W-Modellmotoren 3W 110iR2 twin cylinder inline gas engine

Or...

Kolm 100 or 150 or Valach VM 120i-4T twin cylinder inline 4-stroke gas engine

Vogelsang Aeroscale, www.team-aeroscale.com

DU-BRO 32 ounce gasoline fuel tank

Servos: 6—200 oz-in for flaps (4) and ailerons (2)

Markings:

Prop badges, step, stencils and other marking decals in smaller scales are available from Mick Reeves. 1/4 scale versions forthcoming. See <http://www.mickreevesmodels.co.uk> or email mickreevesmodels@gmail.com.

"Hurricane Rivet Plates" vinyl graphics--email info@callie-graphics.com \$8.00

Covering:

Rib tape: Quarter Scale Warbird Kit pinking tape, <http://www.pink-it.net>

1 yard Sig Koverall Rudder, elevator, ailerons

4 yards 3/4 oz glass cloth plus resin

8 yards 1.4 oz glass cloth (wing), <http://www.expresscomposites.com/>

1/32" strip tape Simulated fuselage stringers



Fuselage Assembly

This section shows the fuselage construction for an electric motor. Most of the fuselage construction is the same for a gas motor so it is not covered elsewhere. The exceptions are described in “Fuselage Assembly--Gas Motor.”

The wing center section must be framed and its upper surface sheeted before fuselage construction can begin. Fuselage assembly uses the inverted horizontal crutch method. That is, a mid-fuselage frame (crutch) of ¼” square balsa is laid down over the plans on a flat surface of wood or sheet rock to which parts can be pinned. The bottom half of the fuselage is assembled inverted on this crutch. After sheeting most of the bottom half, the wing center section is aligned and permanently attached. The fuselage is then set upright, resting on the wing. The upper formers and sheeting are added after the tail is attached.

The Hurricane fuselage has lots of low-stress surface area aft of the CG and a very short nose. Therefore, all sheeting aft of the cockpit must be lightweight 4-6 lb contest grade balsa covered with lightweight glass cloth and a thin layer of resin and paint or else the airplane could be hopelessly tail heavy.



Cut all formers and fuselage parts. This requires about 8 hours of work with a scroll saw, disk sander and drill press. Fit the Hacker 150 motor to the 3/16” ply former F3 using four ½” ply (or eight ¼” ply) spacers plus four M6 x 1-1/8” cap screws and washers. Omit the spacers if a Hacker 200 motor is used. Remove the motor during fuselage assembly.

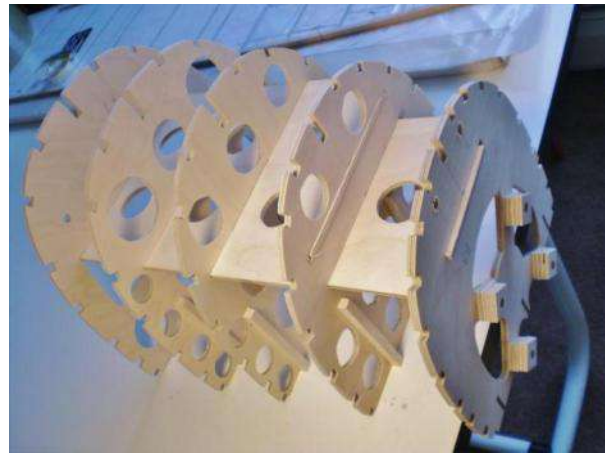
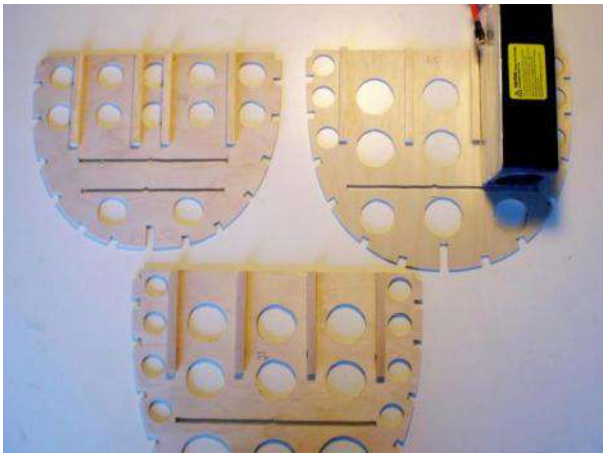

Add ¼” square battery alignment guides to formers F4 thru F6.

Verify that the chin parts fit before assembling them over the crutch.

Note how F3 must dangle over the edge of the work bench.

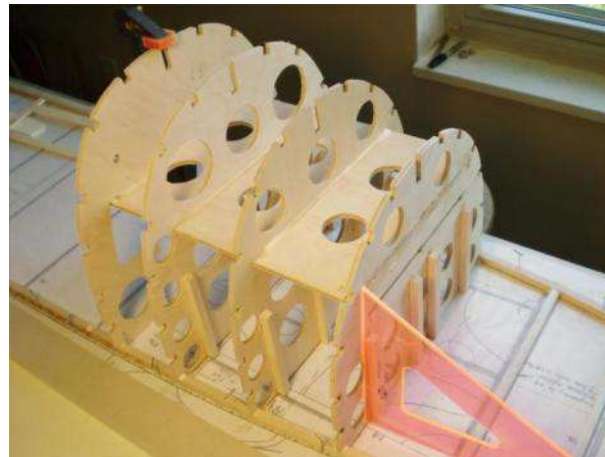
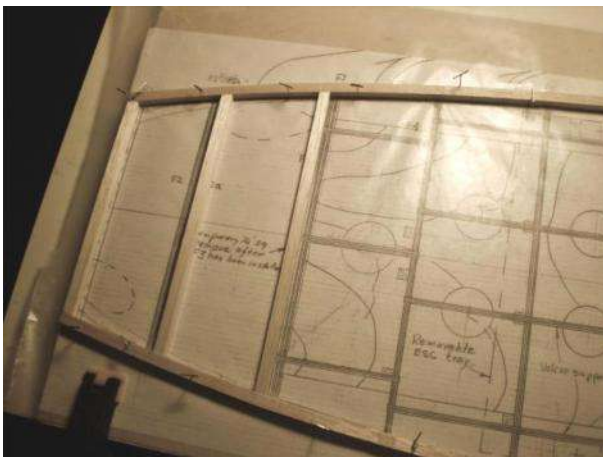

Pin the crutch to a flat surface over plans covered with waxed paper. Glue formers F4 thru F7 to the crutch. Verify that each is vertical or else the batteries may not fit.

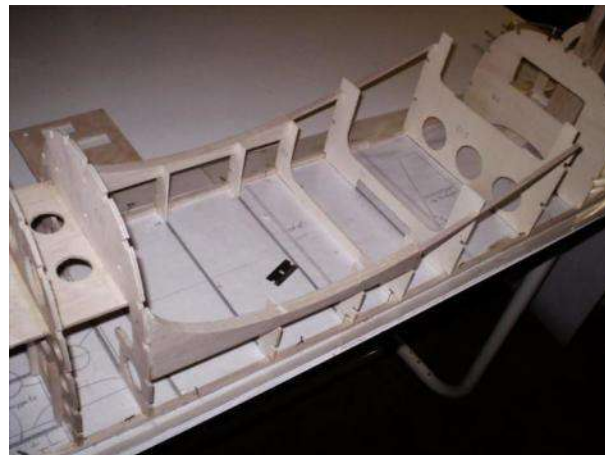

Install formers F8 thru F14. Add the wing saddle from F7 thru F12. The tabs on F11 will insert into the wing to attach to the rear spar.

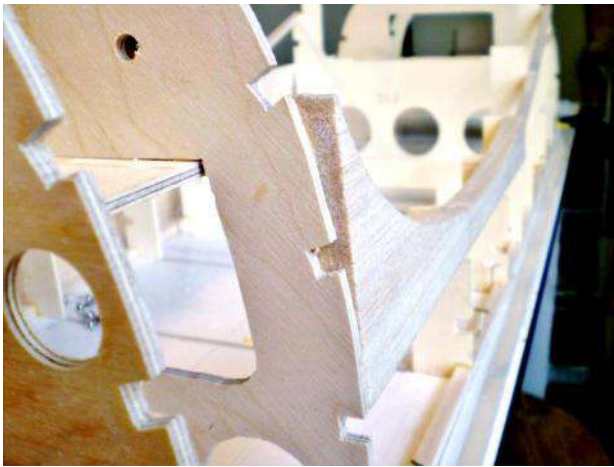

Plane the wing saddle to blend into F7.

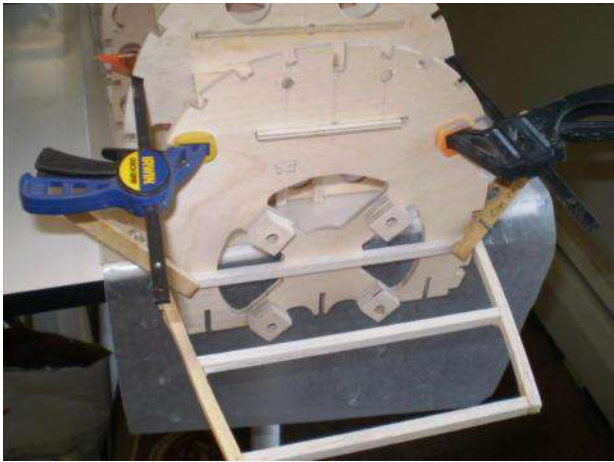

With crutch hanging over the edge, glue the firewall F3 in place. Before glue sets, *trust but verify* that the LiPo batteries will fit.



Add some stringers to the nose area to support the nose formers. Leave the bottom open for now.

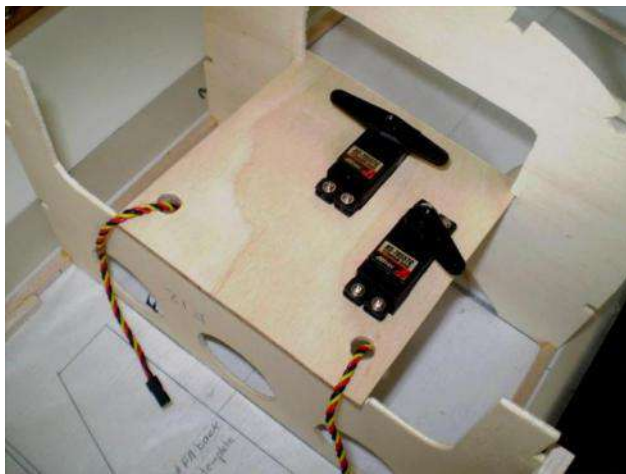

Fit the alternate position elevator (instead of in the tail) servo and rudder/tailwheel servo tray between F12 and F13. The receiver, its battery and the audio card may also be installed here. The servo tray will be accessible thru the bottom of the wing when the radiator is removed.

Select either Robart #657 tailwheel assembly or Messoletta tailwheel strut. Robart is 1 ½ oz lighter. The Messoletta strut, shown here, is more scale, more shock-absorbing and more expensive.



Mark the positions of the rearmost formers, F22 and F23, on the crutch. Slide the crutch off the end of the building board and glue F22 and F23. Use a square to make them vertical. Attach the tailwheel to former F21 and glue it in place, tilting it backwards 10°. Install the lowermost stringer at the same time to hold F21 at the required angle.

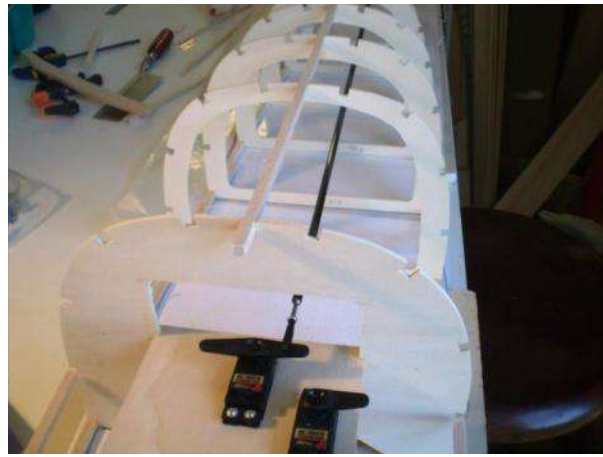
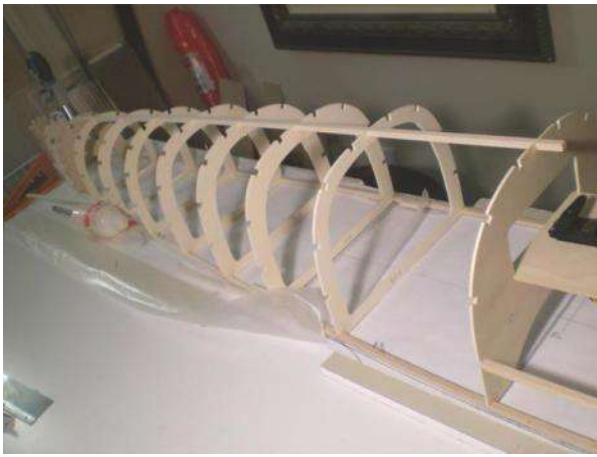

The rear lower formers are now in place, ready for the remaining stringers to be installed.

Install a carbon-fiber tailwheel pushrod while access is open.

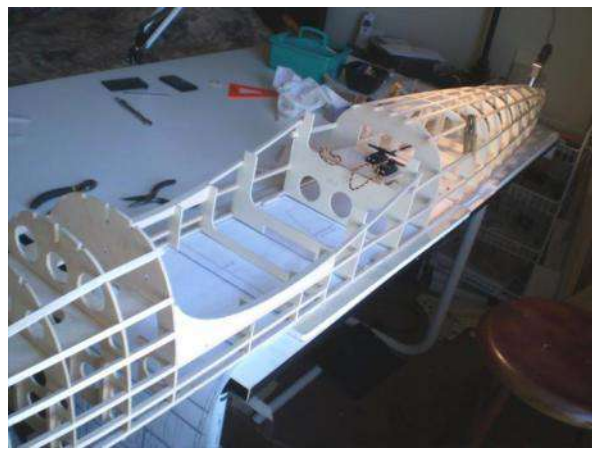

Complete the installation of the stringers of the lower half of the fuselage.



Sheet the fuselage with 4-6 lb Very Light $3/32'' \times 4 \times 36''$ balsa sheet.
IMPORTANT: Use only contest grade 4-6 lb balsa sheeting aft of the CG or else the plane will be tail-heavy. The wing saddle area is now ready to receive the wing center section.

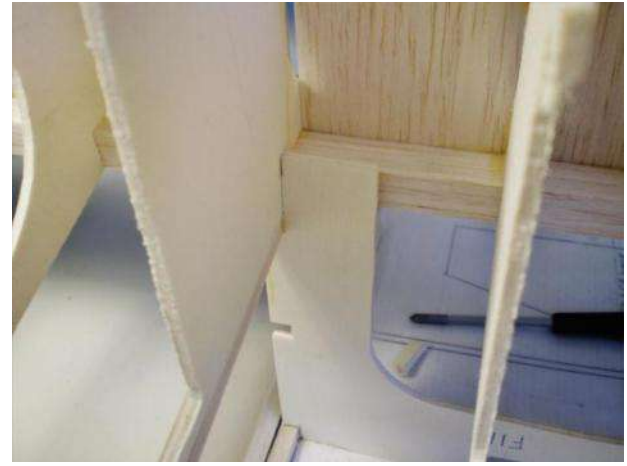

Lay the wing center section on the wing saddle (shown here without upper surface sheeting for clarity). Rib 3 and Rib 3a contact fuselage former F12. Rib 3 also contacts formers F11 and F12 and the rear spar. Adjust and align if necessary.



Cut slots in the upper wing surface for the tabs in F11 and F12. Glue the wing to the wing saddle and former 7, clamping the leading edge of the wing to F7. Tabs in F11 and F12 project into the wing slightly ahead of the spars. Glue balsa blocks to these, attaching them to ribs 3, 3a and the spars.



For extra strength, use a long 3/16 drill bit to drill thru these tabs, into the hardwood spar. Then epoxy a 3/16 dowel to pin the tab to the spar. (Jeff Quesenberry's idea. Thanks, Jeff.)

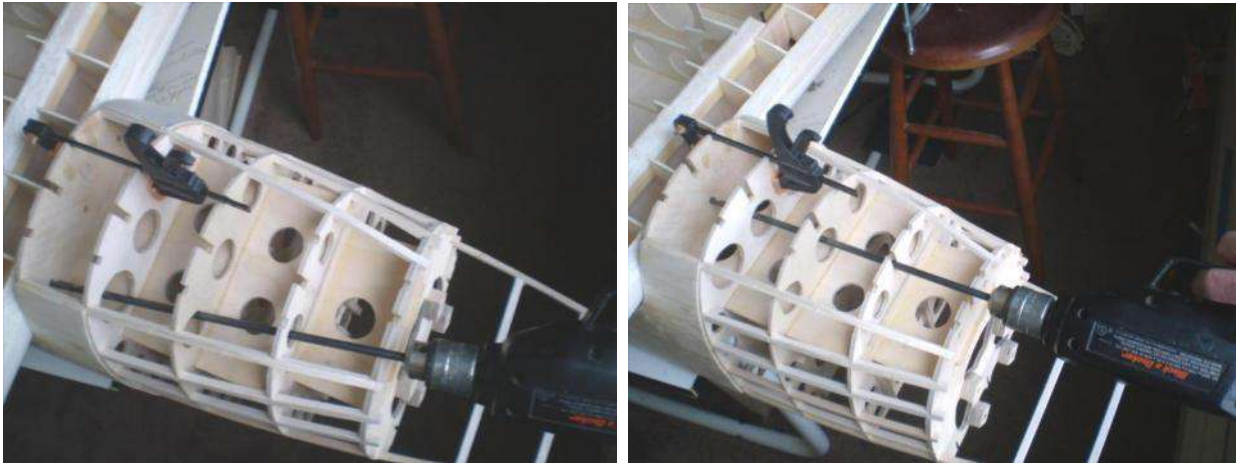

Using a 1/4" x 12" drill, drill three holes in the leading edge of the wing.

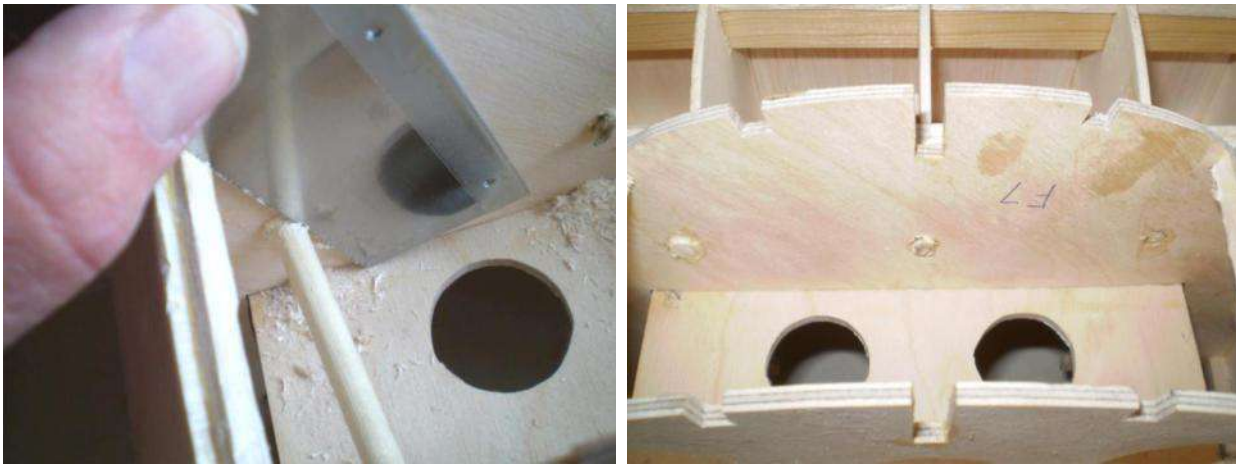

Glue three 1/4" dowels into the wing and F7. Wet each hole and dowel with glue, shove the dowel in place and cut it off with a razor saw.



Cut the remaining ¼” sq. stringers for the nose, slightly oversized. Soak in hot water and pre-bend. The bolts in the landing gear holes are a convenient bending tool. Glue the center keel and stringers in place. Secure with pins and clamps until the glue dries, then trim to length. Plane them to the formers if necessary.



Install wing filet formers F11A and F13A. Glue a 1/8” sq strip to the inside edge of the lower wing filet. This increases its gluing area.



Glue the lower wing filet to F13A and the lower fuselage. The inner corner must be exactly one inch from the center of the fuselage. Tape in place until the glue dries. Turn upright and ...

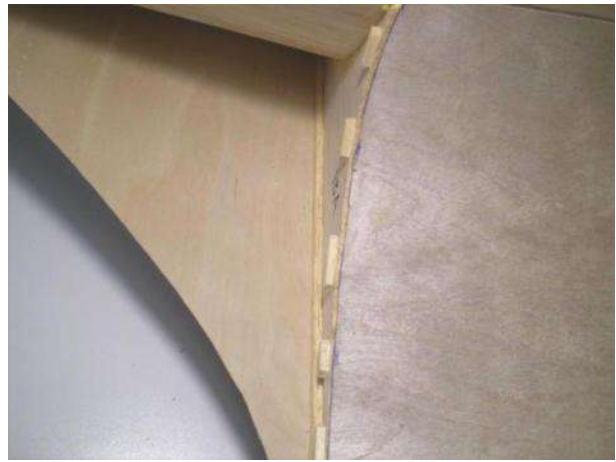

Glue the 1/64" ply middle upper wing fillet to F11A, F13A and the upper wing surface. Attach some 1/8" sq strips along the rear edge to support the rear fillet.

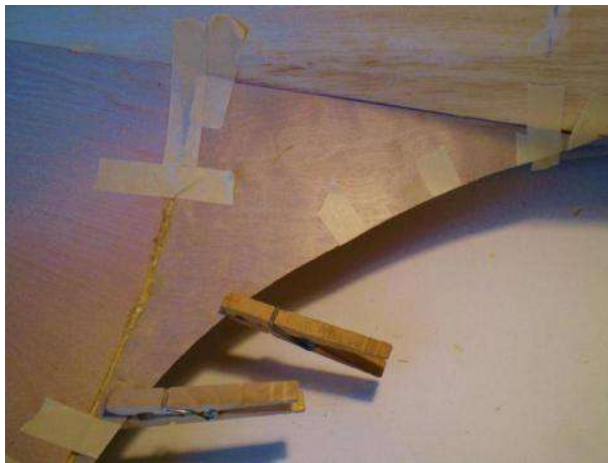

Glue the lower 1/16" ply fillet in place. Turn over and trim the upper edge to the lower fillet. Apply drywall spackle to the fillet seams to feather to a smooth surface before glassing.



Rough-cut the forward wing fillet. Cover it with spackling compound. Sand to final shape.

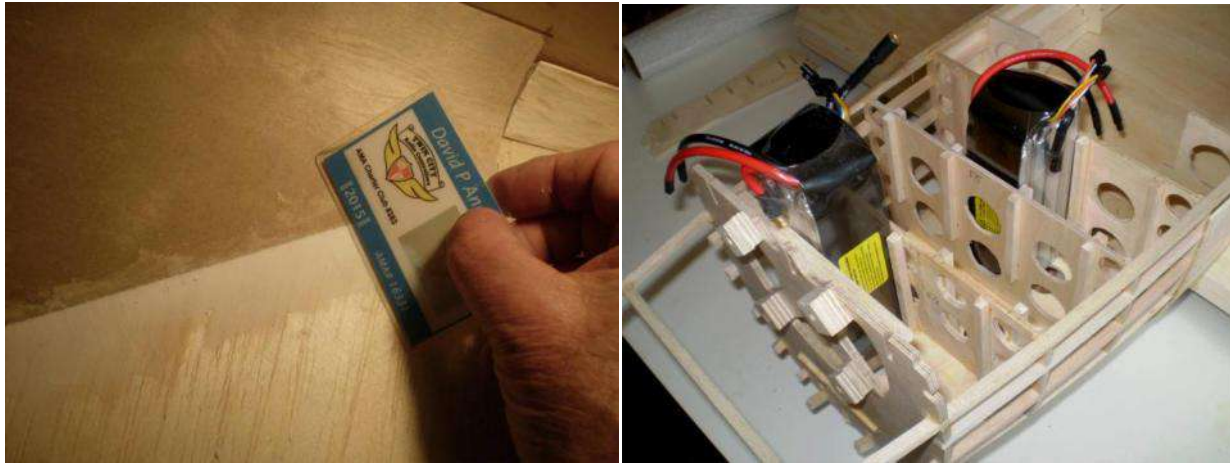

Feather the edges of the middle wing fillet with spackle. Use your RC club membership card as a spatula, then sand. Verify battery fit before attaching the fiberglass chin cowl.

IMPORTANT: The fiberglass chin cowl is made about a ½” too long in order to accommodate a variety of motors. For the motor shown, trim the rear edge of the cowl so that the fiberglass cowl is 12-5/8” long. Alternatively, position the cowl so that the distance from the center of F6 to the front edge of the cowl is 12-5/8”. Or don’t trim the cowl in order to lengthen the nose by a non-scale ½ inch. (No one will notice and your secret is safe with me.) For best alignment, install the motor and spinner backplate, and place the cowl ¼” behind the backplate.



Lay the fiberglass cowl in place. Note how it is slightly transparent. Trace the stringers and formers on the outside of the cowl with a pencil. Remove. Clean the inside surface of the cowl with acetone or other oil-removing solvent. Apply slow-cure epoxy or polyester resin to the stringers and formers with a disposable brush. Also apply resin to the inside of the cowl using the tracings as a guide. Clamp, tape and pin the cowl in contact with the stringers and formers.

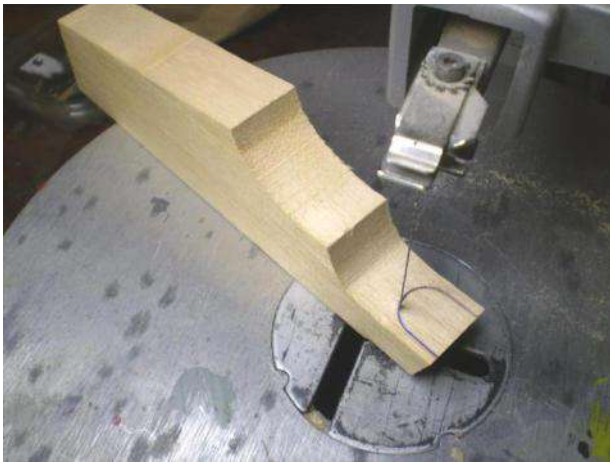

Cut the tail wheel fairings from 1" soft balsa using a scroll saw or bandsaw. Round the edges and fit around the tail wheel. Glue the rear fairing in place after all painting is complete and the CG has been measured. In the unlikely event that tail weigh must be added, cut into the fuselage behind the tailwheel and install lead weights. Cover the hole with the fairing.



Turn the fuselage upright. Position the stab saddles in place without gluing. Lay a straight stick on the stab saddles and sight from the rear to the top of the wing. The stick should be exactly parallel to the top of the wing. Trim the stab saddles if necessary. Fit and remove the stab.

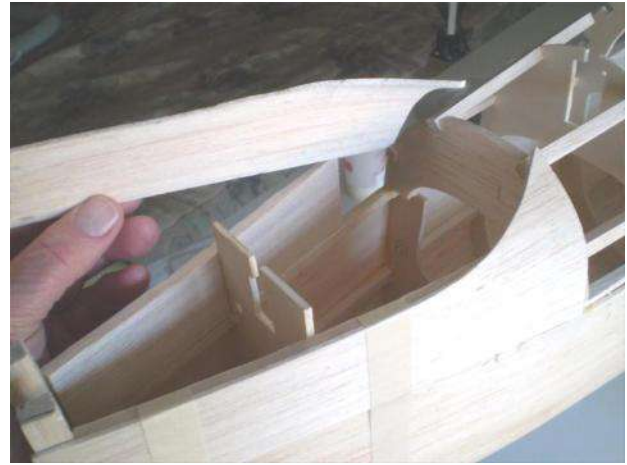

Bevel the upper forward corner of each stab saddle. Install stringers. Cut the stab saddle skins (the pattern is on the plans) from 3/32" soft sheet. Wet the outside surface with hot water, bend and tape in place without glue. Remove when dry. The shape will be retained.

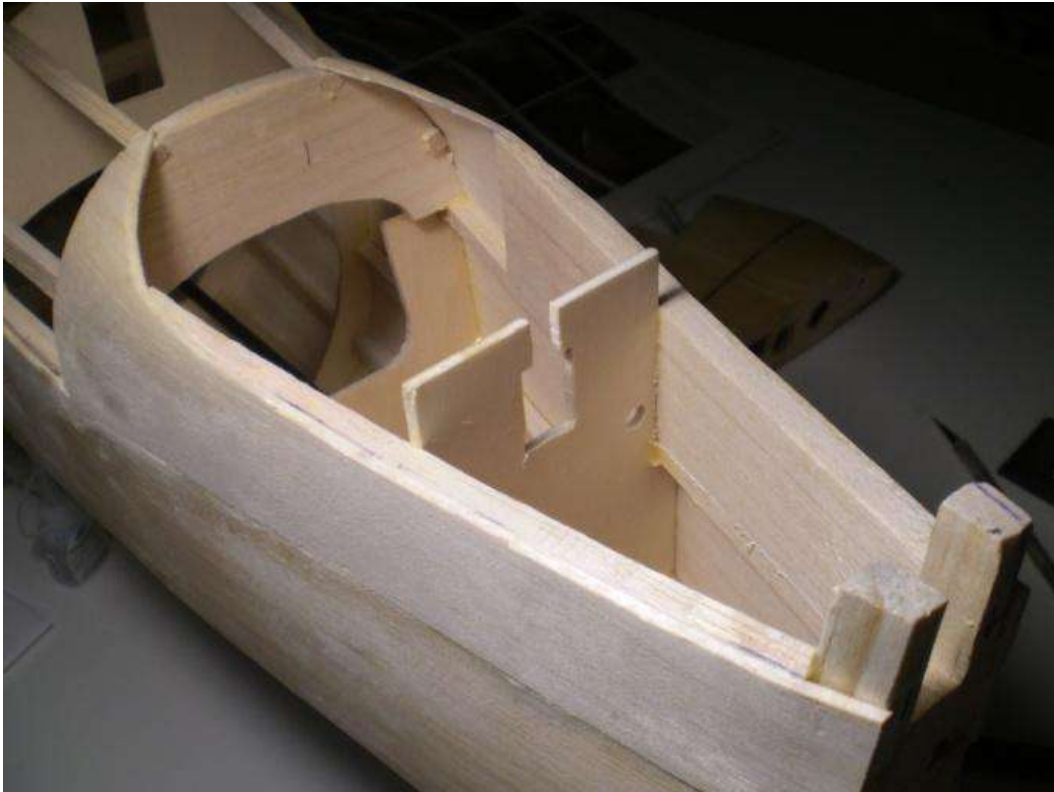

Glue the stab saddle skins in place.



Trim to final shape using the removable stab as a guide. Or use the one-piece stab as a guide.

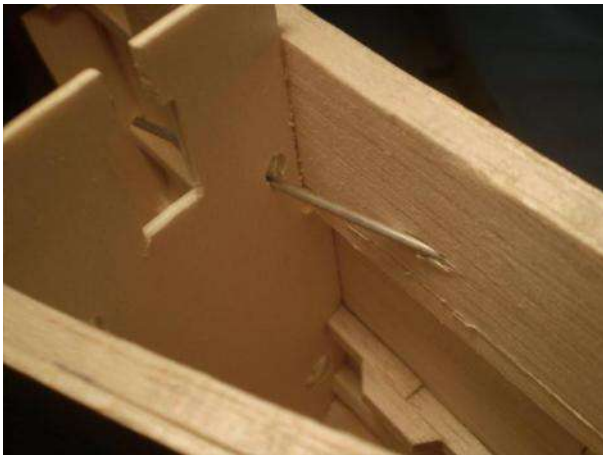

Install 3/32" aluminum tube rudder cable guides. Point them at the rudder servo. Epoxy in place.



Epoxy the LiPo battery brackets in the nose. Epoxy hardwood 1/4" sq stringers to which the dummy exhausts will be attached. This area will also be an air exit for the electric motor. It can be sheeted over for the gas engine version. Note how a long ball driver can reach the lower electric motor bolts thru holes in the nose formers.

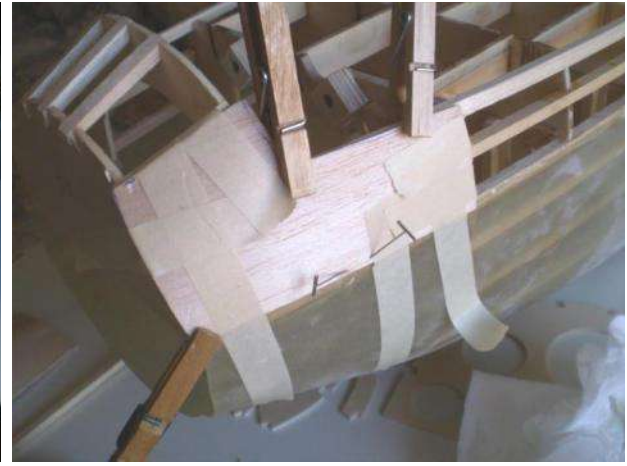
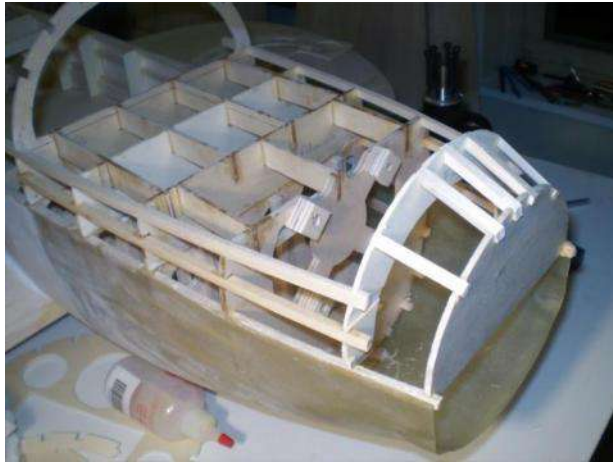

Install F1 and nose stringers. Sheet the nose area from F6 forward.



Apply SaraWrap or waxed paper to the frame and glue the hatch formers and stringers in place.

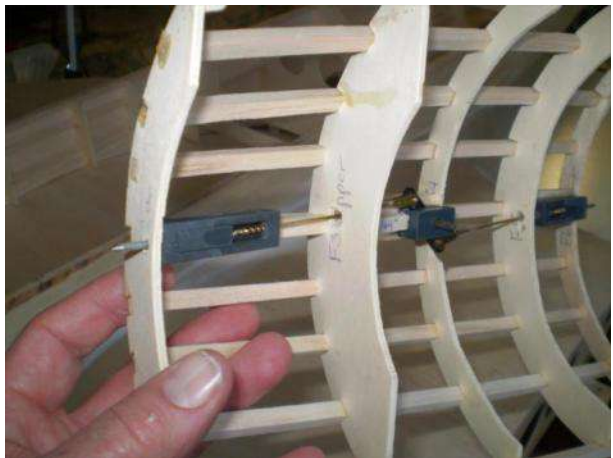

Install the hatch release mechanism before sheeting the hatch. Details 4 Scale Hidden Latch System shown. In the event that the hex driver release fails, remove the prop and spinner; push the pin back with a wire.

Lay Saran Wrap or other thin plastic or waxed paper on the frame to protect the frame from glue, install the hatch and sheet the hatch while it is in place.



After installing and testing the rudder cables and elevator pushrod, epoxy the stab in place. Cut away the cross-pieces of most of the rear formers to save weight. They are no longer needed.



Epoxy the fin in place with the rudder attached for alignment. The leading edge of the fin locks into a notch in F20. Glue and reinforce it with blocks (not shown).

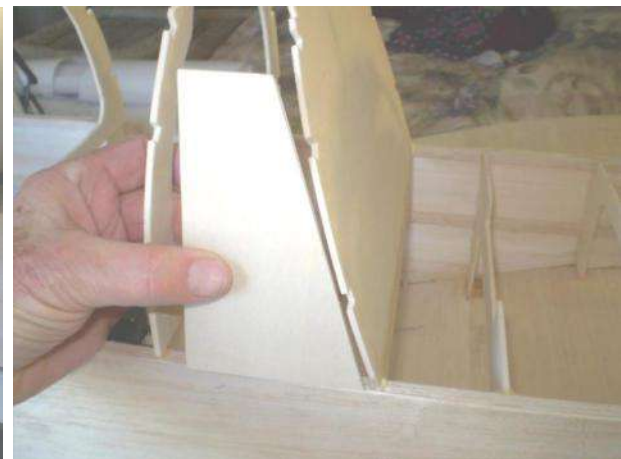

Install the upper formers. Tilt formers F10 and F11 back 18° using the template on the plans.



Fit and remove the pilot's seat before completing stringer installation. All stringers are $\frac{1}{4}$ " square except the canopy base stringer from F10 to F13 which is $\frac{1}{8}$ " x $\frac{1}{4}$ ". If a sliding canopy is elected, the $\frac{1}{4}$ " sq. brass canopy rail replaces this stringer. The top three stringers between F12 to F14 should be hard balsa to resist sagging.

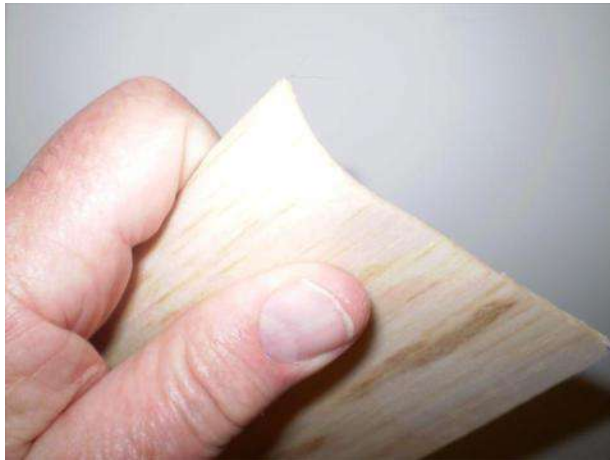

Wet the outside surface of $\frac{3}{32}$ " sheet balsa with hot water and bend to the fuselage shape. (Don't wet both sides or else it will crack when it dries.) Glue it to the fuselage frame and hold it in place with tape, T-pins, clothes pins, etc. IMPORTANT: Use 4-6 lb lightweight contest grade sheet balsa aft of the cockpit. If you don't, the result will be severely tail-heavy. But use heavier, stiffer balsa below the cockpit to avoid sagging between stringers.



Complete the sheeting of the fuselage. Balsa canopy rail increases the gluing area for the canopy. Alternatively, a sliding canopy rail can be installed.

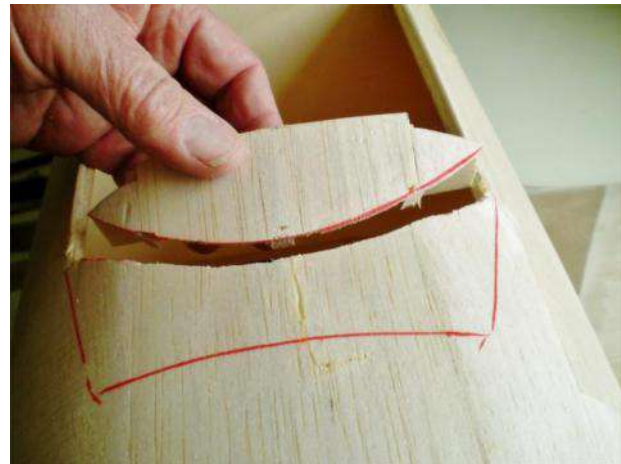

Shape the headrest area as shown. Fill holes with spackling as needed. Using the canopy, trace the outline of the windscreen. Cut away excess material behind the windscreen where the instrument panel will be mounted.

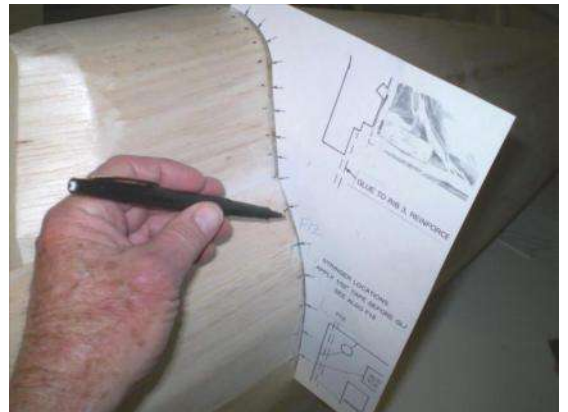
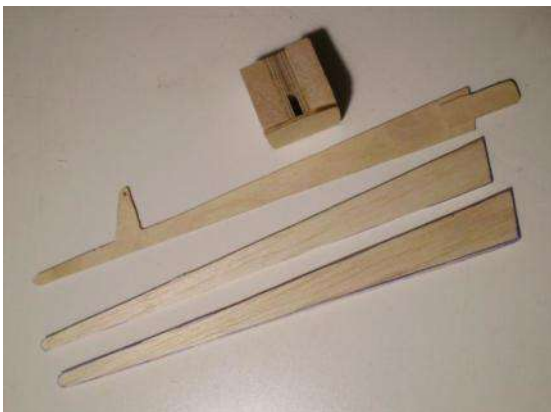

Removable antenna mast is 1/16" ply base between 2 layers of 1/8" balsa. Ply tab on base inserts into slot in ply and balsa block. Glue the block to the back of F14. Using the templates on the plans, mark the stringer locations at positions F13 and F19.



Draw the stringer positions between F13 and F19 with a straight edge and a fine felt-tip pen. To avoid confusion, start with the centerline (at crutch) and work upward and downward. Then lay 1/32" or 1/16" (identical results) masking tape over these lines before glassing. This will create a slight bulge to simulate stringers. More than 80 feet of tape is required! Note that the Koku-Fan and Nye drawings show stringers on the bottom of the fuselage but photos are vague at best, e.g., Aero Detail 12.



Cover with 3/4 oz glass cloth and resin. Apply Klass Kote primer with a mini roller, sand with 150 grit.

After painting, stringers should look like this.

Another method, developed by Jeff Quesenberry, uses 3/32" sheeting plus 1/32" balsa strips instead of 1/8" sheeting in the rear fuselage. This method is intended for covering with iron-on fabric which is thicker than fiberglass cloth.

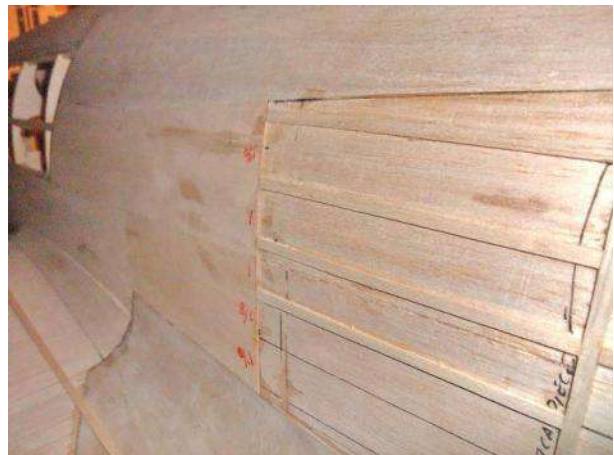



Apply a fillet of finishing resin and microballoons with a palette knife to the tail-fuselage junction. Sand smooth. This fills remaining gaps and adds strength.

Using the fuselage former patterns F8 & F18, make a fuselage cradle. Line with window A/C foam. Use it to hold the fuselage while working on the bottom. Sanding the first coat of primer on the fuselage requires about 6 hours of work but the results are worth it.

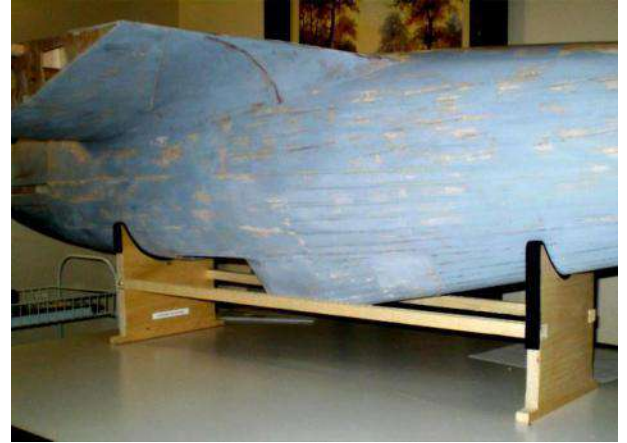

Assemble the 6 exhaust stacks, 3 on each side. Cut $\frac{3}{4}$ " deep slots to fit formers and stringers. Glue in place after painting. Space around stacks provides cooling for the electric motor and batteries that may not be necessary for the gas engine version.



Choose or make an oil cooler air scoop. Use it to construct the fairing under the chin (see Carburetor Air Scoop Installation notes).

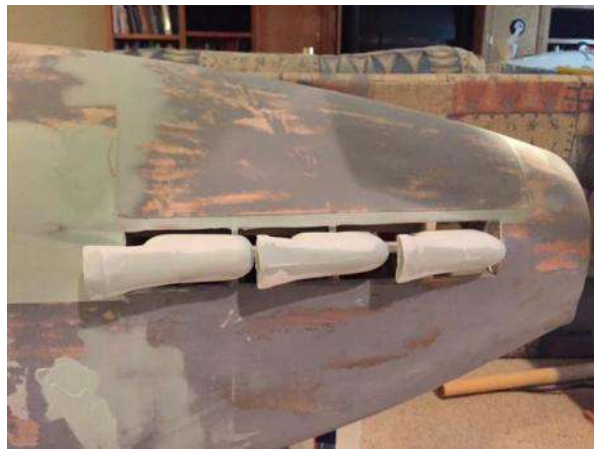

Install the ventral fin and seal it with filler. Complete the exhaust stack installation.



Complete the tail fairings by masking off the tail fairing area. Apply light weight spackling compound in thin layers to prevent cracking, waiting for each layer to dry before applying the next. Sand to shape. Re-apply masking tape. Harden the surface by applying thin cyano adhesive. Lightly sand with 180 grit sandpaper.

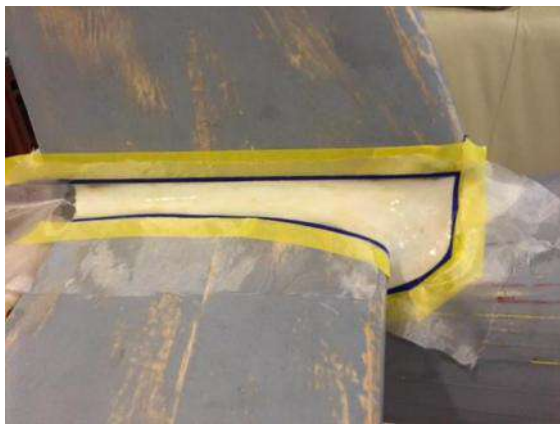

Light weight glass cloth is applied with epoxy resin. After curing, the excess is trimmed away with a razor blade.



Install wing filets by same method. Alternatively, cut the stab filet from 1/64" ply. Pattern on plans.



Rivet plates are vinyl stickers from Callie Graphics.

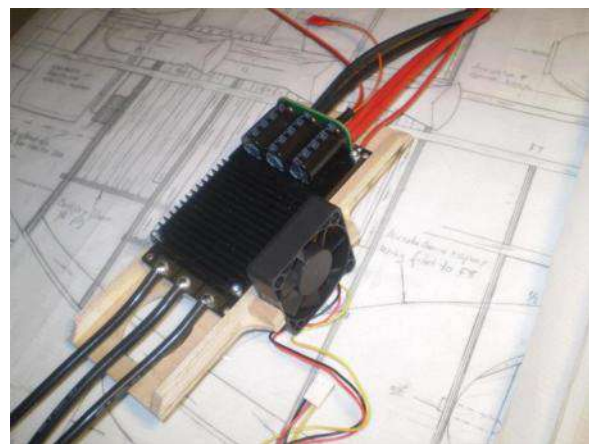

ESC in its holder, ready to install in fuselage.

Fuselage Assembly--Gas Motor

Most of the fuselage construction is the same as for an electric motor so it is covered in "Fuselage Assembly." Only the exceptions for gas are described here.

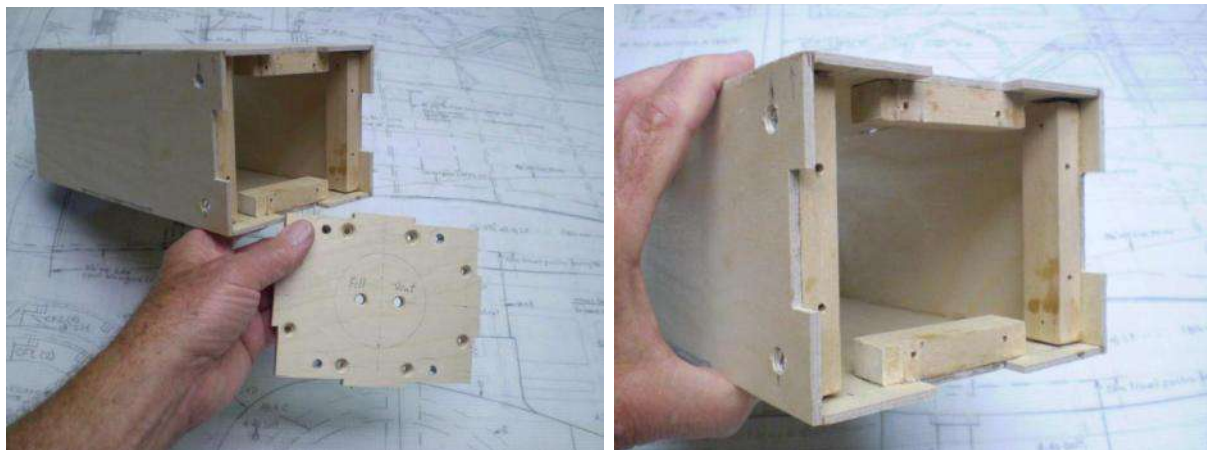

Tank box with removable firewall.

Mount ignition battery, ignition module and throttle servo on top of the tank box. The removable hatch also provides access to the needle valves.

IMPORTANT: The fiberglass chin cowl is made about a 1/2" too long in order to accommodate a variety of motors. For the motor shown, trim the rear edge of the cowl so that the fiberglass cowl is 12-5/8" long.

If nose weight is required, attach a removable 1/4" x 4" x 12" ply shelf to the top of the tank box extending forward. Install lead duck decoy weights to this shelf.

Use a 6" Tru-Turn or Dave Brown P-51 spinner with lightening holes in backplate for cooling.



Inverted gas engine mounting, removable upper hatch. Enlarged firewall for 105CC inline twin Quadra 52.

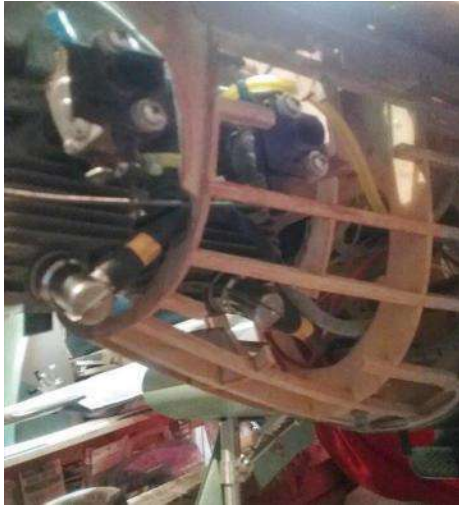

Fitting the lower fiberglass cowl: While clamped in place and position marked with a marker, electrical tape is applied on where to trim the cowl to meet the fuselage. Remove the cowl and trim with a Dremel fiber cutoff wheel. Apply thin CA to the edge to prevent splitting. Apply final trim with a Dremel sanding drum and finish off with 40 grit on a sanding block. Re-apply CA. The cowl need not be removable. The forward stringers can give gluing surface to the cowl and dampen vibration.



Here we see the flight pack on top of the engine box and the ignition module strapped to the bottom of the motor box; throttle rod poking out.

Radiator Construction

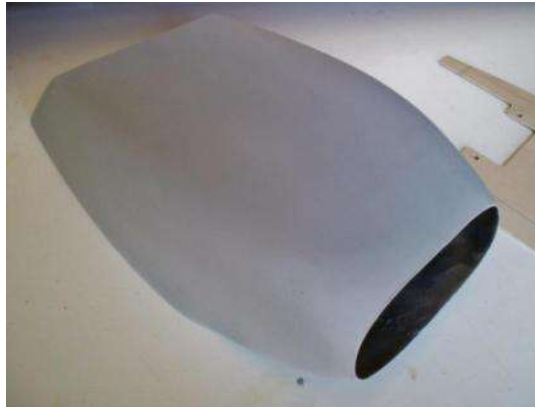

A fiberglass/polyester radiator is available from Micko Aircraft and Accessories. See Parts List. Glue it to the ply radiator base with polyester resin. Speakers can be installed like the wooden version. The following describes the construction of the wooden version.

The radiator is constructed from light-weight balsa and ply. Lightweight balsa is preferred in order to save weight and to ease carving. The radiator is removable via four $\frac{1}{4}$ x 20 nylon bolts. This provides access to the tail servos and perhaps other radio gear.

The electric version includes two 4" speakers that emit the recorded sound of a Merlin engine, one facing forward and down, the other facing rearward and down. This optimizes the audio for fly-bys.

The gas version provides a path for engine cooling air to pass over the top of the wing inside the fuselage and exiting thru the rear opening in the radiator. The front of the radiator is left open in order to increase a vacuum in the radiator via the venturi effect.



Glue up 4 sections cut from 2" sheet balsa each 1-5/8" wide for the front intake. Vertical grain will make carving easier. Set aside for now.

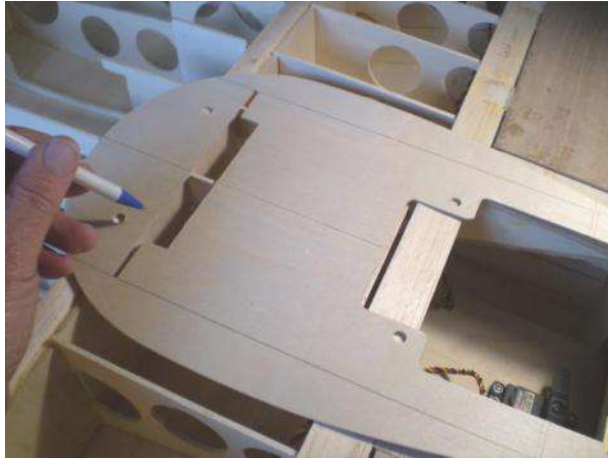

Lay the radiator base or its pattern on the wing (the bottom of the wing need not be sheeted at this time). Mark the locations of the mounting holes. Drill and tap 4 holes each $\frac{1}{4} \times 20$. Harden the threads with thin CA glue. Re-tap ("chase the threads") after the CA has set.



Assemble the top, bottom and sides over the ply base. Do not glue the bottom surface at this time. Include it only to align the sides. Bevel the inside of the front lip in order to expose more of the front speaker.

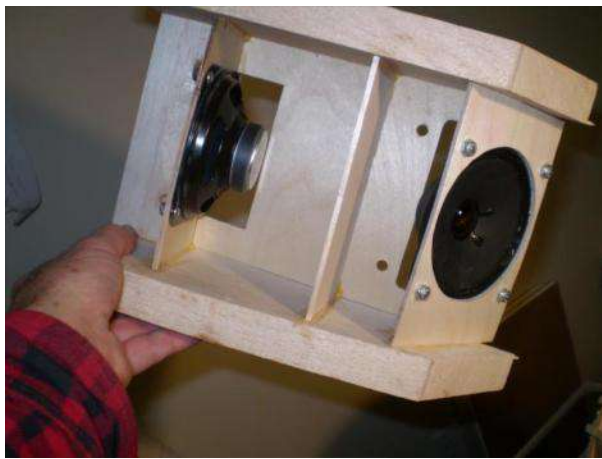

Install the speakers and speaker baffle (electric-powered version only). Glue the lower surface in place. Note the ball-driver access holes in the lower surface.



Cover the speakers with paper to protect them from dust and paint during the remainder of the construction. Bevel the inside lower lip of the intake per the side view on the plans.



Glue the front piece in place.



Trim the corners of the speaker supports flush with the radiator base in order to clear ribs 2.

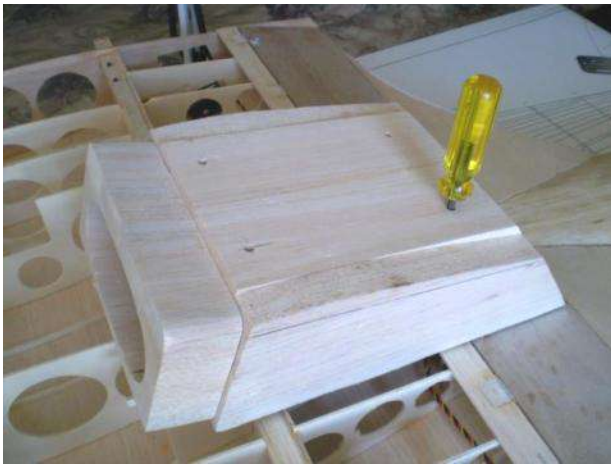

Fit the radiator to the wing, insert a ball driver and verify that all four nylon bolts align, and the radiator lays on the wing without gaps. Trim and shim if necessary. Remove.



Cover the inside of the speakers with masking tape to keep out dust. The radiator is now ready for final shaping by rounding the edges. Use the ply base, the fuselage side view on the plans and photos of the full-sized as guides. Plane the sides flat to match the views and photos, then round the edges. Let's begin...



Rough-cut the edges to match the base with a band saw. Plane the sides to simple flat curves.



Kinda boxy now. Next, round the edges with a razor plane.



Use a woodcarver's gouge or a round file or both to form the concave curve above the intake. Fill flaws with spackle. Sand and sand and sand until it's perfect. Then sand some more.

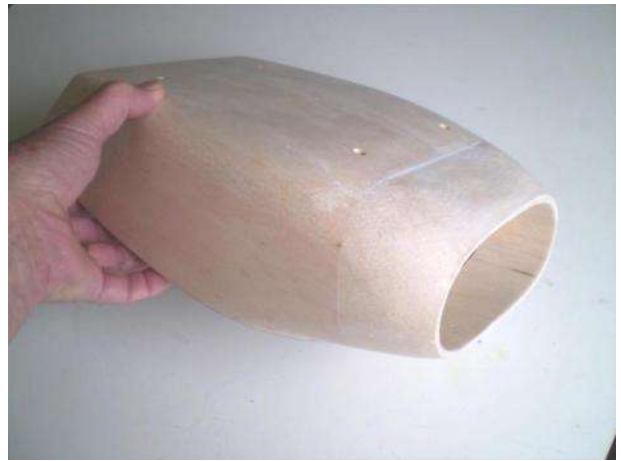

Completed radiator, ready for glassing.



The entire radiator can be covered with one piece of $\frac{3}{4}$ oz glass cloth.

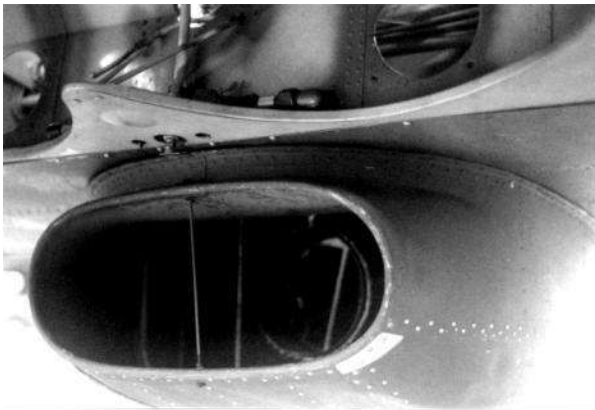

If ya did a good job, it should look like this.

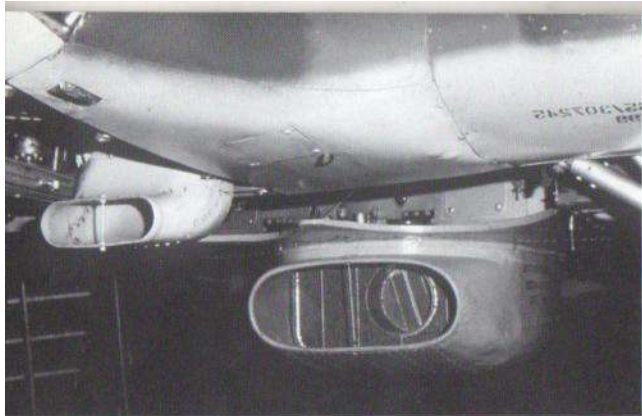
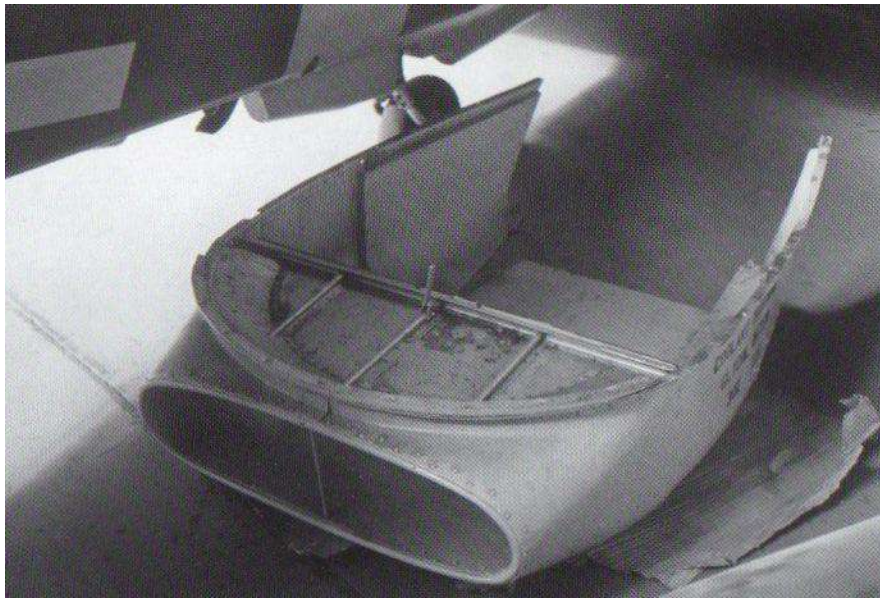

The radiator bath on all Hurricanes is located just to the rear of the landing gear bay. A stencil on the port side states the recommended coolant mixture is 70% water and 30% glycol. This is the later, and most common radiator with the circular oil cooler. The small scoop in the foreground is the carburetor air-intake.

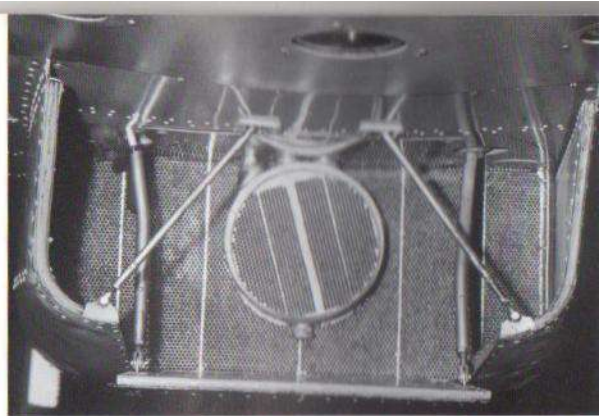

Looking into the radiator bath from the rear, two fixed rods support the extreme end of the bath. Directly behind the radiator are the exit flap actuating rods. A cockpit lever with a thumb release button operates the flap and controls the velocity and volume of cooling air through the radiator. The circular aperture is the back end of the oil cooler.

Oil Cooler Intake Scoop Construction

A fiberglass oil cooler scoop is available. See the Parts List. But if you wish to carve your own, it can be done by using the “lost wax” process. We carve a core from balsa or foam, cover it with 3 layers of 6 oz fiberglass cloth and then remove the core. Let’s begin.

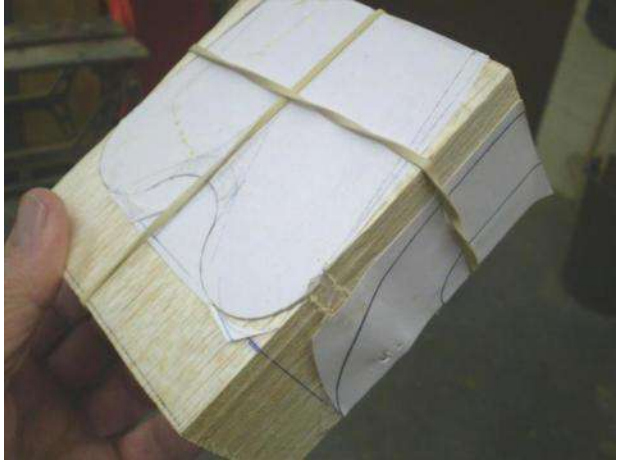
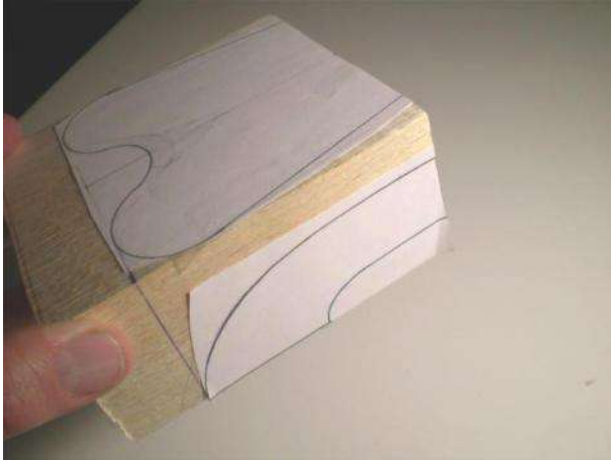

Apply the top views and side views to a balsa block. Cut the top view with a scroll saw or bandsaw and spot-glue the peices back in place.



Cut the side view with a bandsaw.



Break the pieces apart.

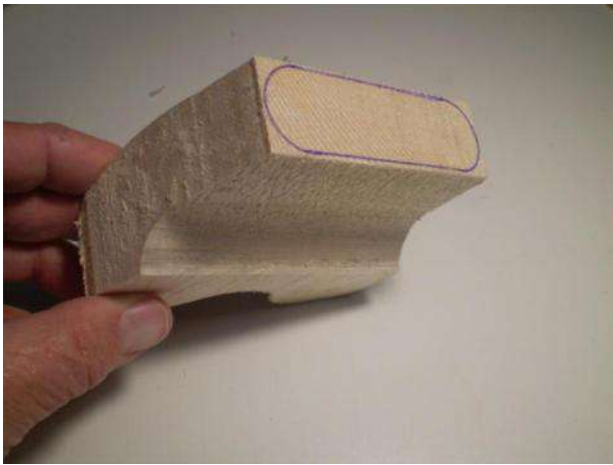

Draw or paste the front view.



Round the edges using an X-Acto knife,

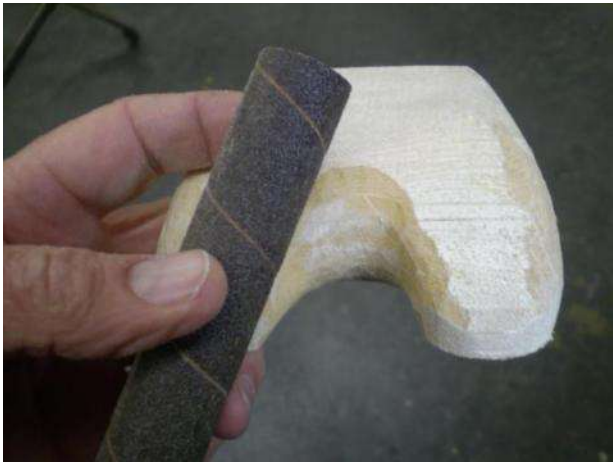

sanding spindle tube, sanding block and sanding paper, using a



photo of the full-sized as a guide.



Apply fiberglass covering.



One can quit here and use the balsa scoop or apply 3 more layers of 6 oz cloth.



Sand the surface. Drill out most of the core. Add primer. After sanding, ready for color.



Alternatively, a fiberglass air scoop is available from Micko Aircraft and Accessories.

And a 3D printed airscoop is available from Trapezoid Consulting, Inc.

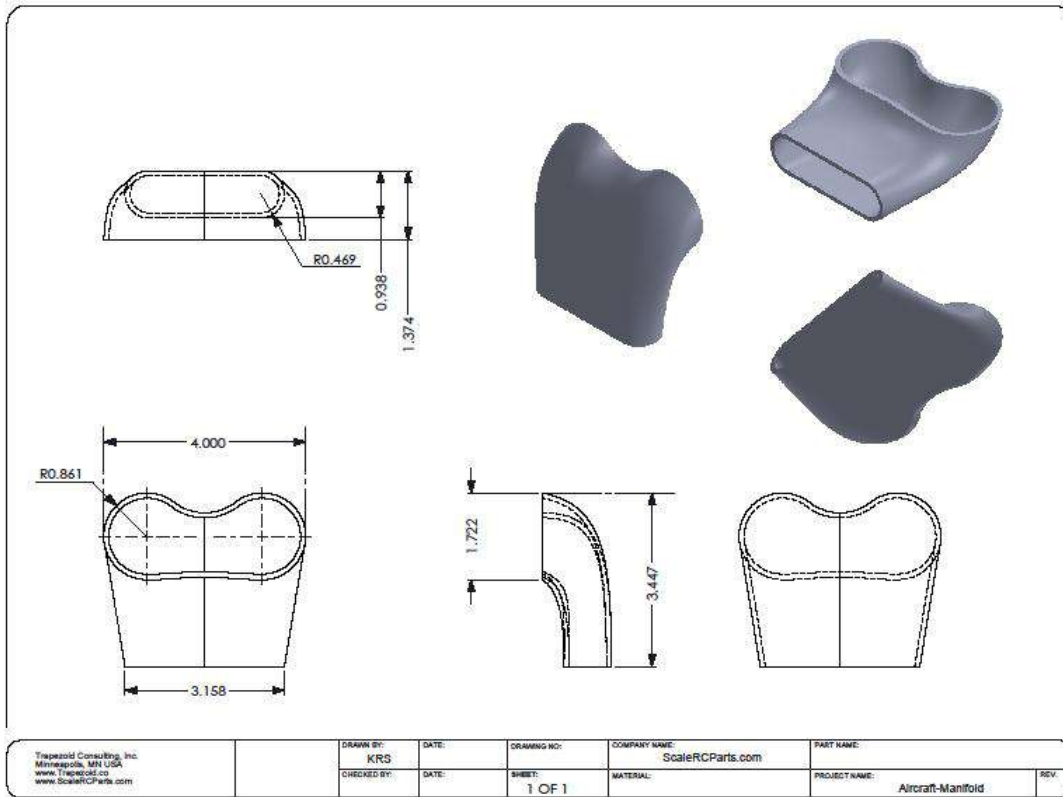

3D printed air scoop available from
Kirk Schneider
 Trapezoid Consulting, Inc.
 629 Tupelo Way
 Chaska, MN 55318
 m952 356 6576
www.Trapezoid.co

Oil Cooler Air Scoop Installation.

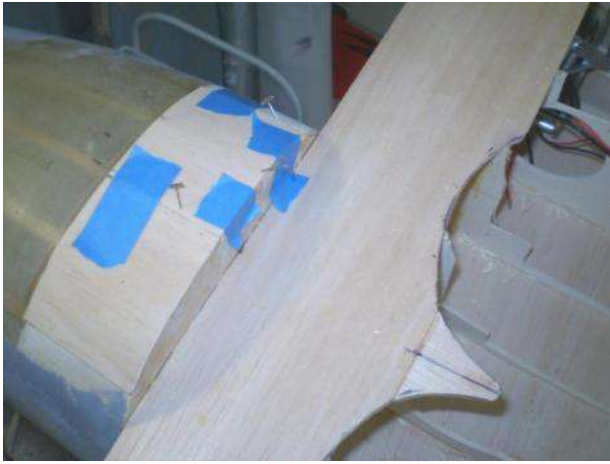

Complete the chin underside sheeting. Select a balsa, glass or 3D printed airsoop.

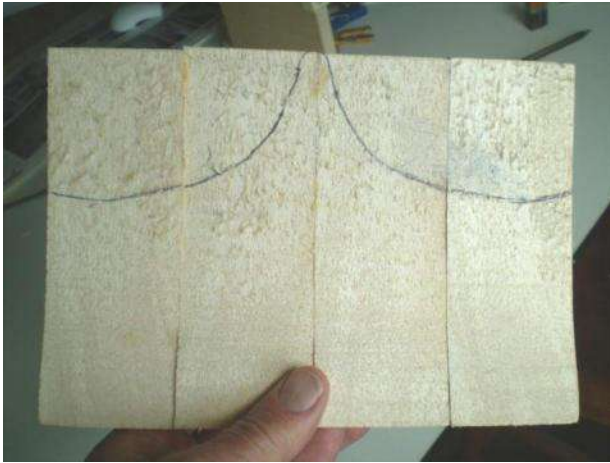

Glue together 4 pieces of 2" x 2" balsa (pattern is on the plans). Trace and cut the top view outline. Then trace the end view outline.



Trace the outline of the air scoop. This area must remain flat after carving. Carve and sand to shape before gluing in place. Fill the remaining space if any with spackling. Sand smooth and cover with fiberglass cloth.

Retract Specifications

If you wish to make your own quarter-scale Hawker Hurricane retracts or adapt an off-the-shelf set of retracts, here are the angles you need to know. Derived from the original Mick Reeves Hawker Hurricane:

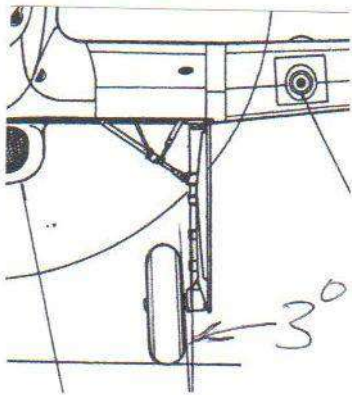

Strut length: 11 ½" to 12" from pivot to axle.

Retract angle: 90°.

Model weight: up to 45 lbs..

Zero degrees toe-in.

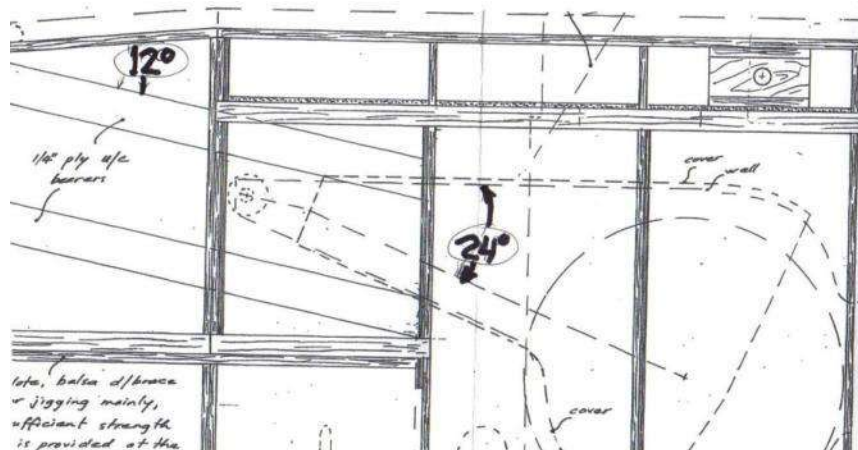
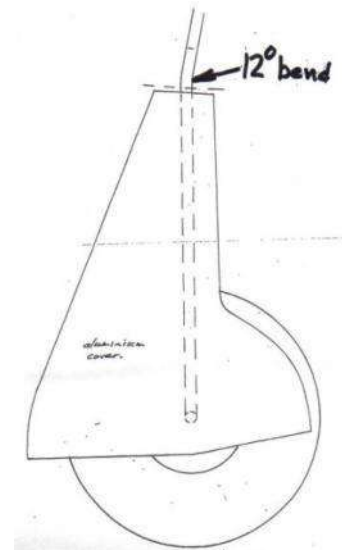
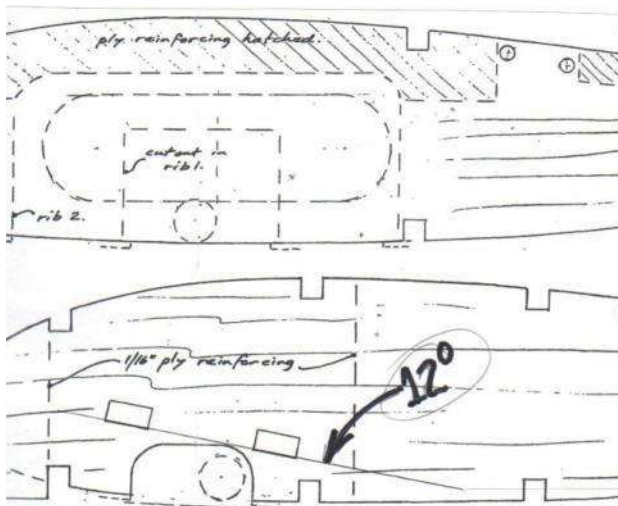

Flaps Assembly

The flaps are Maynard Method flaps construction -- a core of 3/32" sheet balsa between two layers of 1/64" plywood, glued together with epoxy finishing resin. The hinges are sandwiched between the outer (lower) layer of ply and recessed into the balsa core. This combination has proven to be strong and warp-free.



Using the patterns on the plans, draw the flap skin outlines on a sheet of 1/64 x 12 x 24 ply. Note that the upper flap skins are 1/2" shorter in chord than the lower flaps skins so that the flaps' trailing edges can be tapered. Attach to a second sheet of ply with double-faced tape. Cut out the flap skins with a straight edge and a single-edge razor blade. Also cut out the flap cores from 4-inch wide balsa sheet. Apply a light coat of oil with a Q-tip to the hinge pins of 20 DU-BRO Heavy Duty hinges as a precaution against epoxy entering the hinge joints. Wipe off any excess.

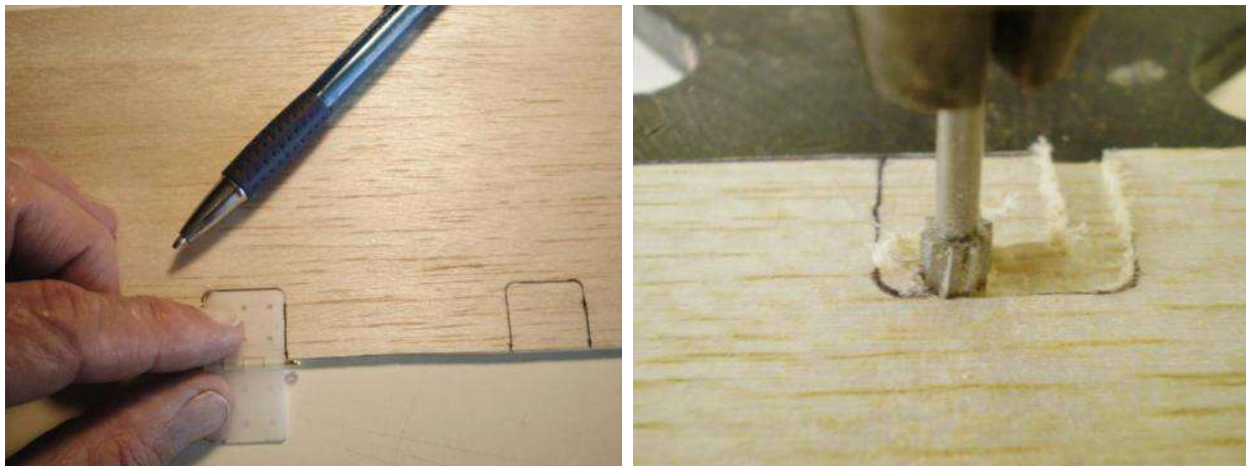

Using a DU-BRO hinge as a pattern, draw the outline of the hinges on the 3/32" balsa flap core at the positions shown on the plans. Score the lines with a razor blade for a clean cut and mill the balsa at each hinge position to a depth equal to the thickness of the hinge body. Use a Dremel router bit in a drill press. Experiment on a scrap piece of balsa to get the depth just right before cutting the flap cores. If you enjoy woodworking, you will experience woodworking ecstasy.

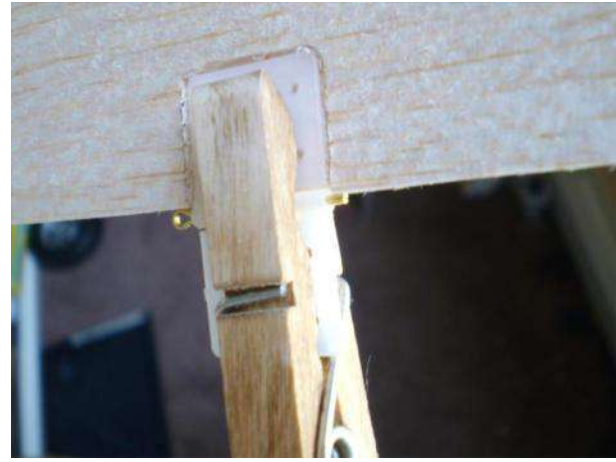
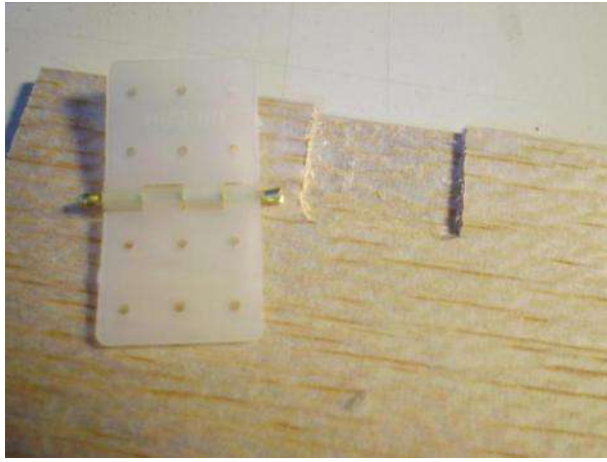

Verify that the hinge fits flush with the surface of the hinge core. Epoxy the hinge in place while being careful to not get glue into the hinge pin. Hold each hinge in place with a clothes pin until the epoxy sets. Using one of those unsolicited credit cards that we get in the mail, squeegee some more epoxy over the hinge to make a flat, flush surface.

Spread a thin layer of finishing epoxy resin to the lower surface of the flap core and the surface of the flap skin. Join together on a flat surface with lots of weights. Cure overnight.

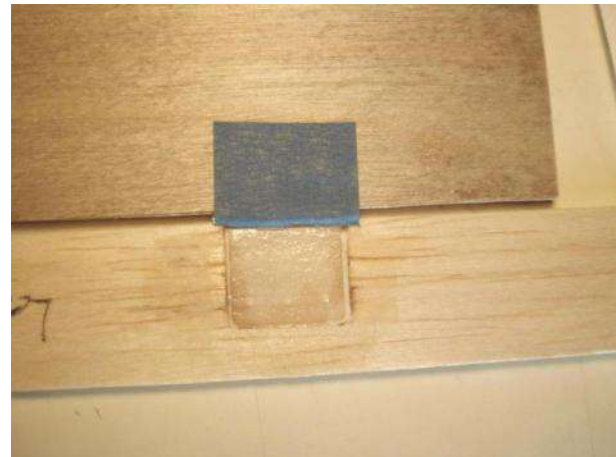

Bevel the last $\frac{1}{2}$ inch of the trailing edge of the balsa core with a razor plane. Glue the upper surface in place with finishing resin. Note that the upper flap surface is $\frac{1}{2}$ " shorter in chord for this reason.

Cut three 1" wide strips of $\frac{1}{8}$ " sheet balsa equal in length to the inner wing panel and the lengths of the flaps in the outer panels. Recess and epoxy the flap hinges into the balsa strips. Cover the flap pins with masking tape and apply a layer of epoxy and microballoons over the exposed hinges with a credit card squeegee. When cured, sand smooth.

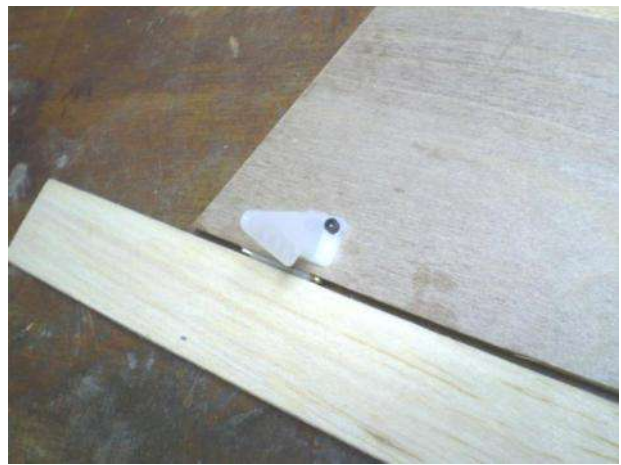

Clamp the flap strip in place and mark a line where the pushrod will be. Remove the flaps and install the flap horns. The flaps are now ready to be installed in the wing.



Glue the flap strip in place on the rear spar of the wing. Make 4 flap pushrods, each 2 1/2" long.



Install the flap pushrods. Adjust for 90° deflection as per full-sized. The servo arm should point at the flap horn when fully down. This gives max mechanical advantage in the full-down position.

Note that the full-sized Hurricane used 90° deflection on landing. But this required full up-elevator to flair. Roy Vaillencourt (see References) recommends only 30° deflection with power on and not attempting 3-point landings. The best flap angle depends on your skill level.



Flaps extended 90° for landing.

Elevator Assembly



The large amount of up-elevator deflection will be needed in certain landing situations.

Like the full-size, the elevator is fabric-covered. Ribs are at scale locations. Half-ribs are glued to opposite sides of a 1/16" sheet base.

But first, hinge extensions and elevator control horns must be constructed.

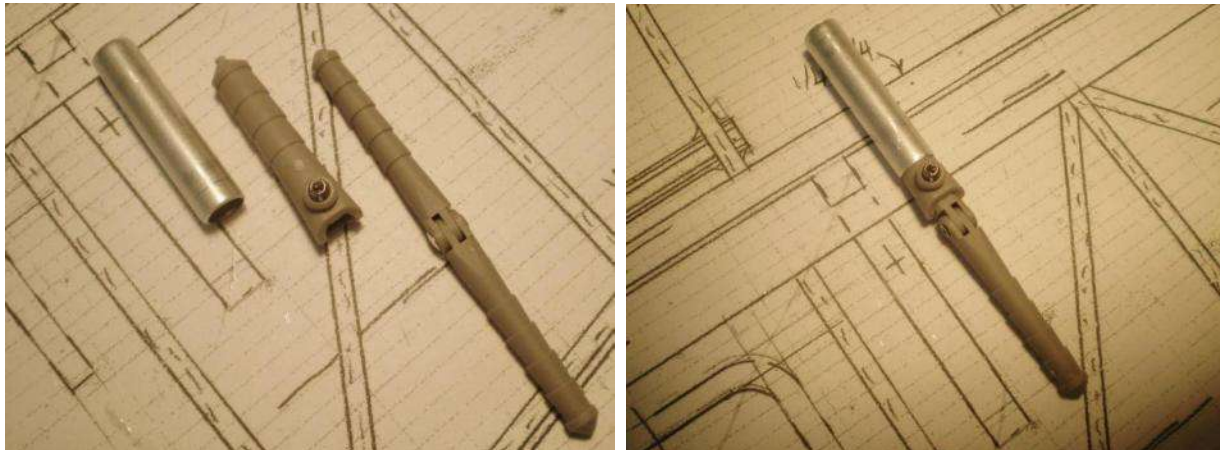

A total of 6 Robart Super Hinge points are required for the elevators. Because the leading edge of the elevator is so thick, the joint of the hinges is located deep within the elevator as shown with a "+" on the plans. This setback requires an extension of the stab portion of each hinge. Cut 6 aluminum tubes (K&S 9/32", Stock #107) each 1 1/4" inches long. Glue these to Robart Hinge Point Pockets. Alternatively, omit the Hinge Pockets and use 1-1/2" long 7/32" tubing—this simplifies installation but the elevators will not be removable. Use epoxy or Gorilla Glue.



Bend two elevator horn wires. (Breiten wire bender shown.) Clamp them in a vise and file a flat on each to receive the set screw of a SIG nose gear steering arm.



Note the forward rake. This provides more up-travel than down-travel and clearance of the rudder post.



SIG SH102 5/32" Nylon Steering Arm. Note the forward rake.



Assemble the elevator over the plans.

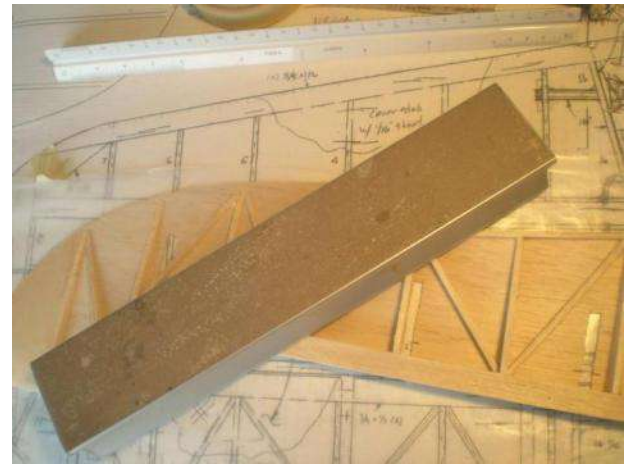
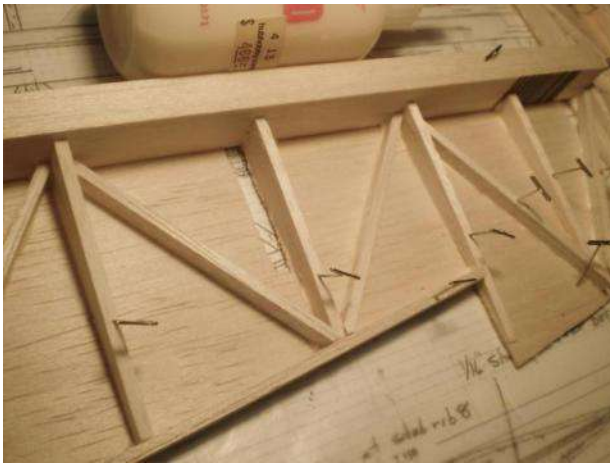

While still on the board, plane the leading edge and cross braces to match the ribs. Then plane the leading edge to match the ribs. Block-sand.



Turn over. Draw a line on the base thru the hinge joint locations. Tape the hinges in position with the set screws all on the bottom side of the elevators. Spot-glue in place. Add the leading edge, half-ribs and cross braces for the other side of the elevator. Plane and sand to the ribs.

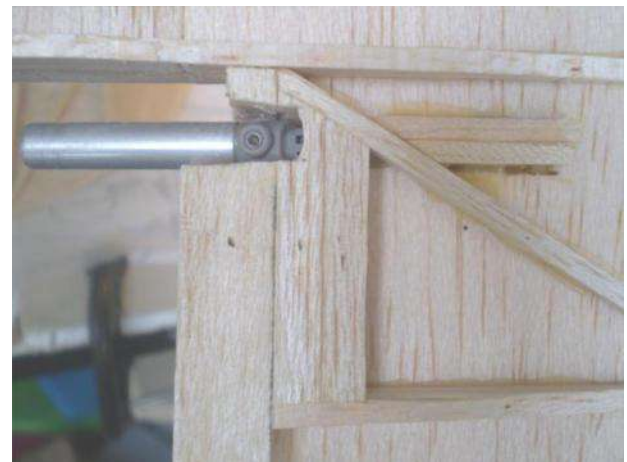

Glue 1/8" sq. reinforcements beside each hinge point. Add 1/4" stick reinforcements along each hinge. Mortise the leading edge to allow at least 30 degrees of hinge rotation. in each direction.

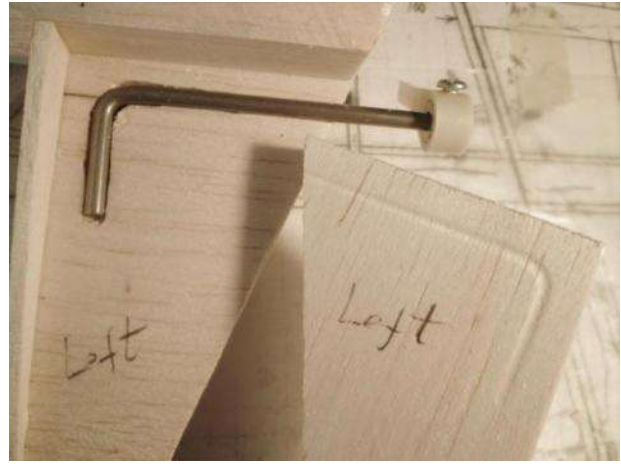

Deepen the groove for the music wire horn with a Dremel tool or round file and fit the wire horn. With the horn in place, press the panel for the top side firmly. This will leave an impression in the balsa.

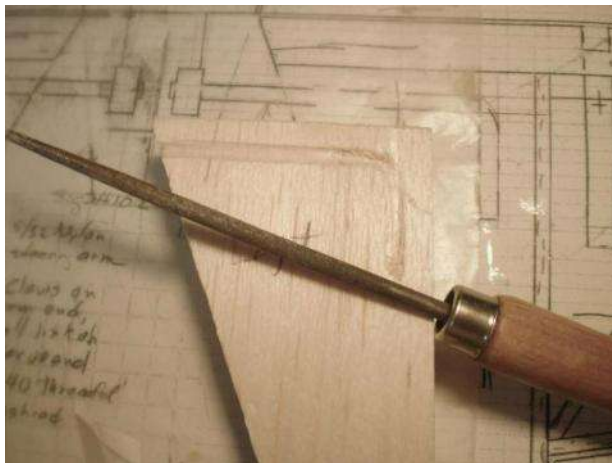

Deepen the impression with a Dremel or file. Test the horn for a tight fit. Coat the groove with epoxy and glue (yellow glue) the end piece in place. Clamp and tape well while the glue sets.

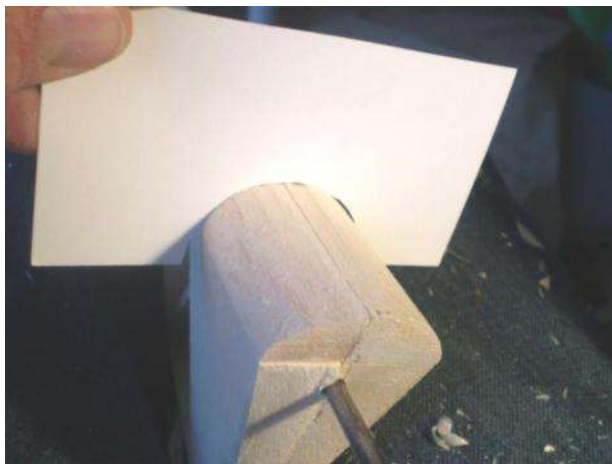

Using the template on the plans, round the leading edge of the elevators. Also taper the inboard trailing edge with a #11 X-Acto knife. Sand smooth.

The elevators are now ready to be mated with the stab and covered with fabric such as SIG Koverall.

Fin Construction

Fin and rudder structure are similar to the stab and elevator. That is, the fin is two sheeted clamshell halves and the rudder is ribs on a base, covered with fabric. Build the stab and elevator before starting the fin because the stab will be needed while shaping the base of the fin. Build the rudder before the fin because the rudder will be needed to align the hinges.

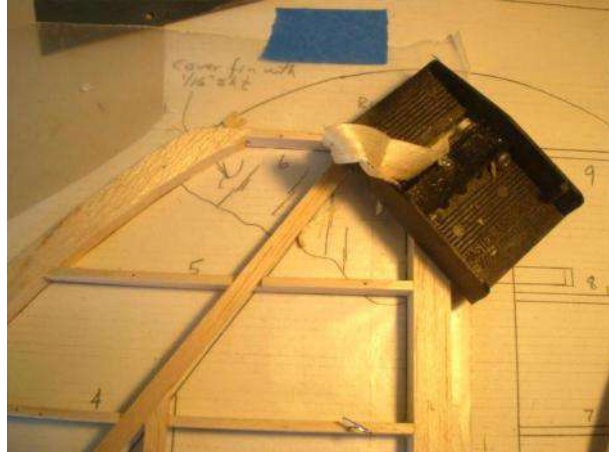
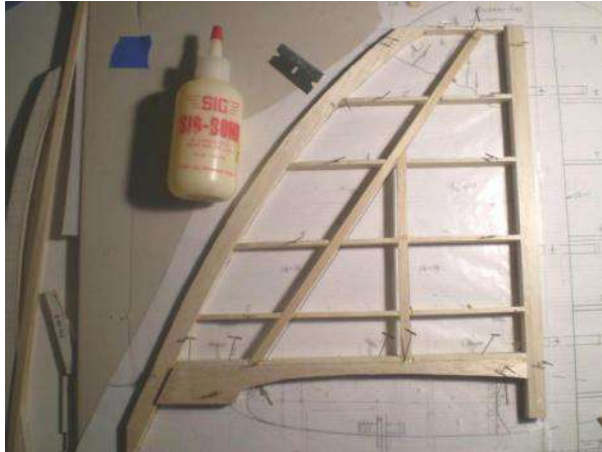

Assemble the fin clamshell halves over the plans. Plane the trailing edge to match the top of the ribs.

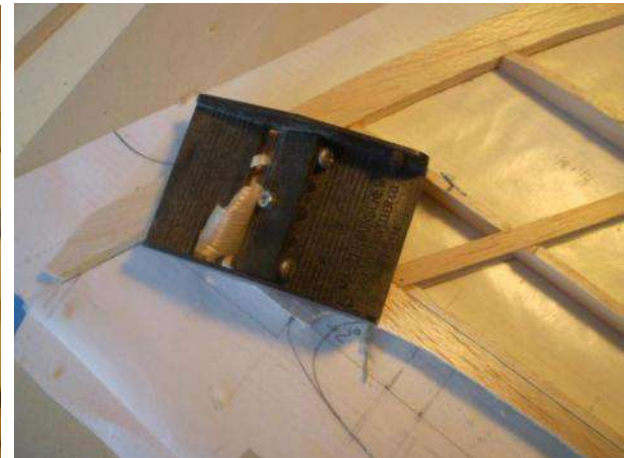

Plane the leading edge and the base to match the top of the ribs.

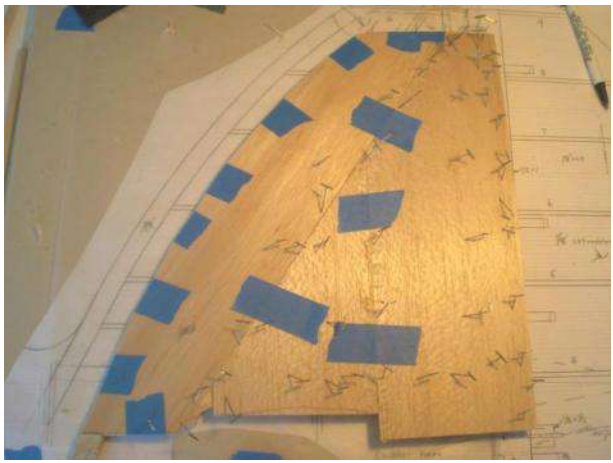
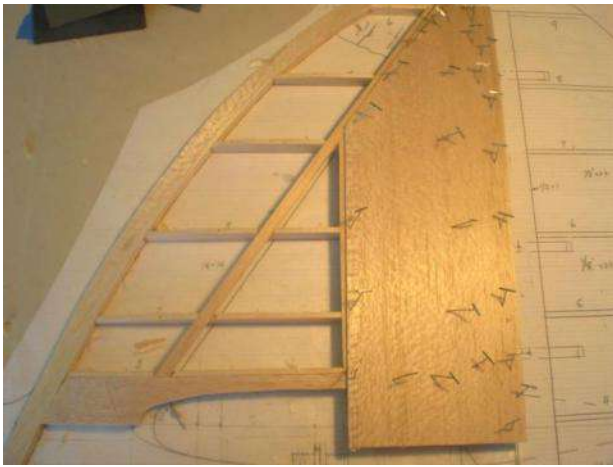

Sheet the fin with 4-inch wide 1/16" balsa. Cut the sheets so that the seams meet on the spars.



Trim each fin half to the contour of the stab center section. The front portion must be beveled. It is easier to do this before joining the fin halves so that the interior can be seen.

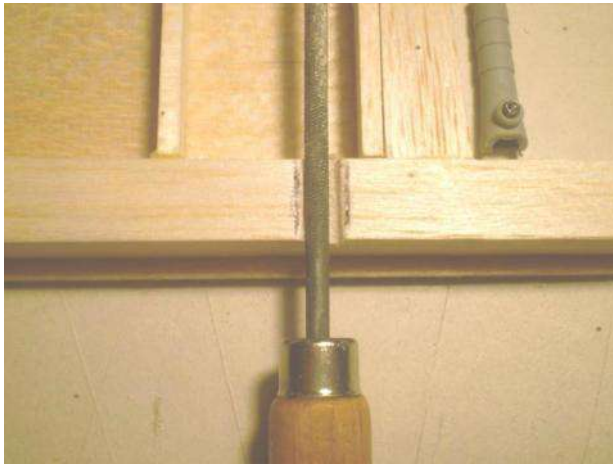
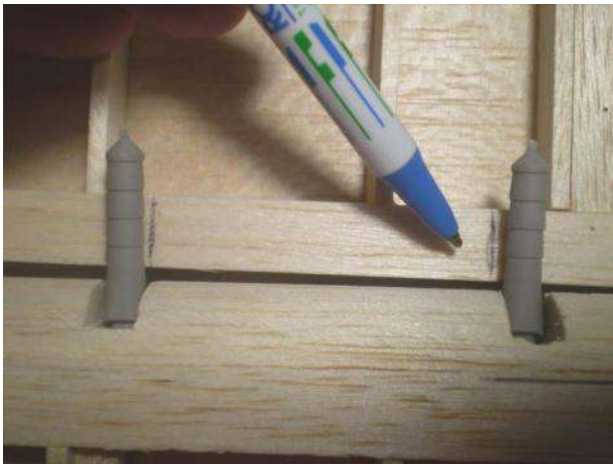

Lay the rudder hinges on the fin's trailing edge and mark their positions. Then file a semicircular groove in each location to match the hinge pockets.

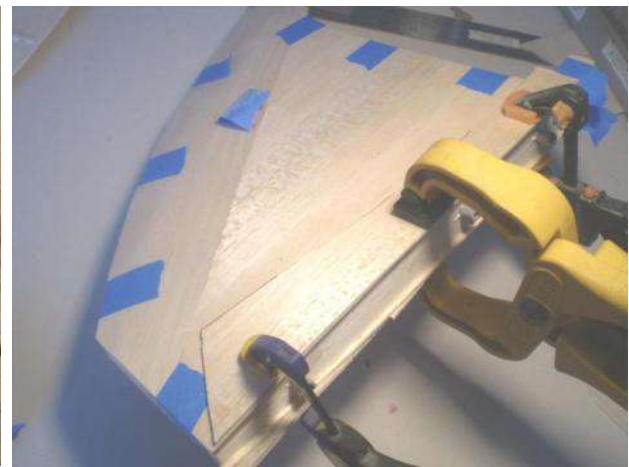

Place the two fin halves together to verify that the holes for the hinges align and fit tightly. Separate the fin halves. Glue the hinge pockets into the fin trailing edge with CA glue. Moisten the grooves. Then apply Gorilla Glue (it will expand to fill small gaps) to the grooves in the other fin half and yellow glue to the rest of the fin half. Place the two fin halves together. Clamp and tape tightly, placing scrap balsa under the clamps to prevent the clamps from marring the fin's surface. Remove any excess Gorilla glue as it oozes from around the hinge pockets.

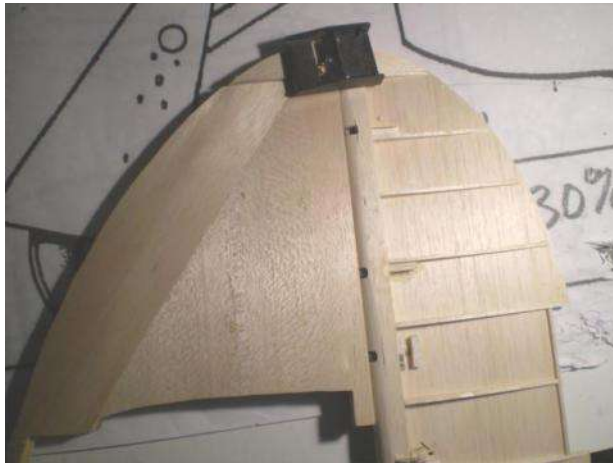

Shape the leading edge of the fin and the top of the rudder while the rudder is in place on the fin. Glassed and primed, the fin weighs 3 ¼ ounces.

The fin of the full sized Hurricane was offset 1 ½ ° to the left in order to reduce drag and increase top speed due to spiral airflow. None of the published three-views show this and it is not observable in published photos. It appears only as a note on the Nye drawings. Small reductions in drag are not important in scale modeling so the offset would be an unnecessary structural complication. Therefore it is recommended to install the fin without offset.



After installing the fin, mask off the LE panel line and spray primer. Lightly sand. Then apply rib stitching, Dynamic Balsa rib tape and leading edge tape.

Rudder Construction

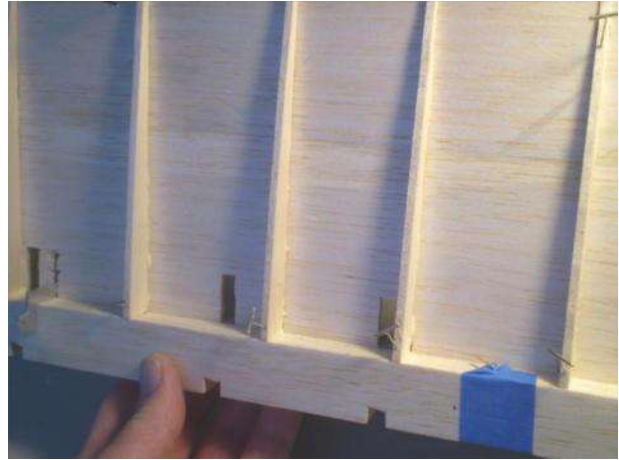

Assemble the leading edge and ribs over the 1/8" sheet base. Turn it over and add the leading edge and ribs to the other side. Easy.



Fit and remove the 1/16" aluminum rudder horn. Trim the horn for a tight fit.

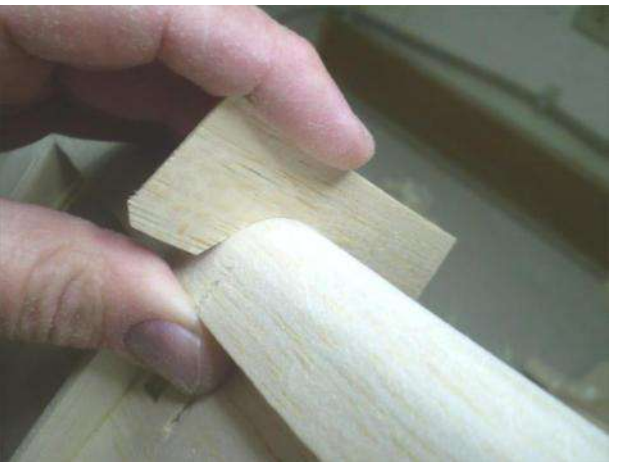

Round the leading edge with a razor plane and a sanding block. Test the shape with a 1-1/8" diameter template.



Sand the ribs to a uniform height with a sanding block. Round the bottom as shown.

Do not shape the top of the rudder at this time. Wait until it is attached to the fin.

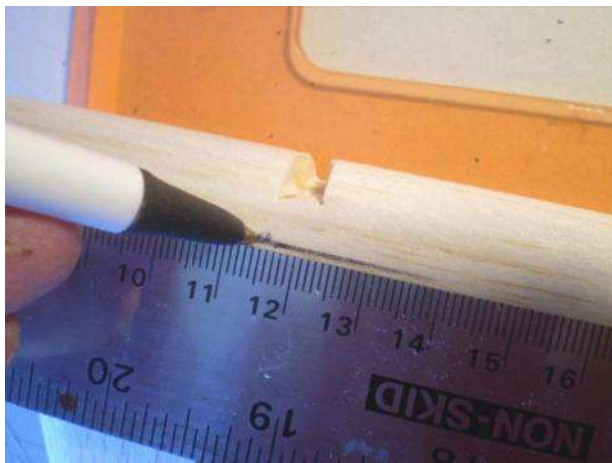

Mark the hinge lines $\frac{1}{2}$ " from the leading edge. Drill a $\frac{3}{16}$ " diameter hole at each hinge location.



Using a #11 Xacto knife and a file, shape each hinge hole allow the Robart hinge to swing at least 60° in each direction.

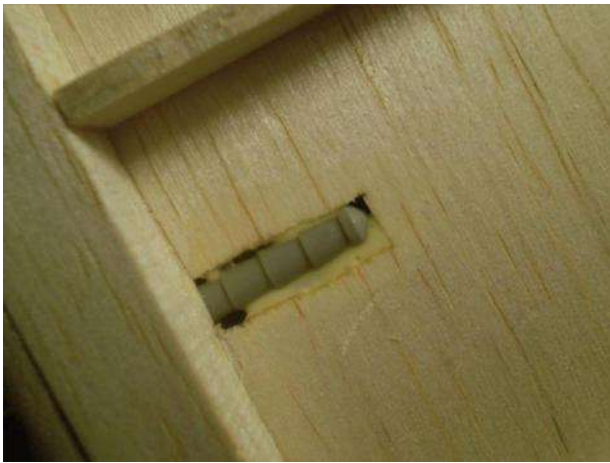

Glue the hinges in place with yellow glue. When dry, enclose each hinge with $\frac{1}{4}$ " square balsa on both sides.



Install the rudder horn after shaping the rudder leading edge. Reinforce with balsa and provide a surface to which the fabric will attach.



Apply SIG STIX-IT to one side of the rudder surfaces. Apply STIX-IT just to the outside edge of the trailing edge and about $\frac{1}{4}$ " of the trailing edge on the other side. Iron on SIG Koverall. Turn over and iron the overlap to the other side. Repeat for other side. Heat shrink the entire surface.



Cut a notch in the rudder's leading edge for elevator horn clearance, non-removable stab only.

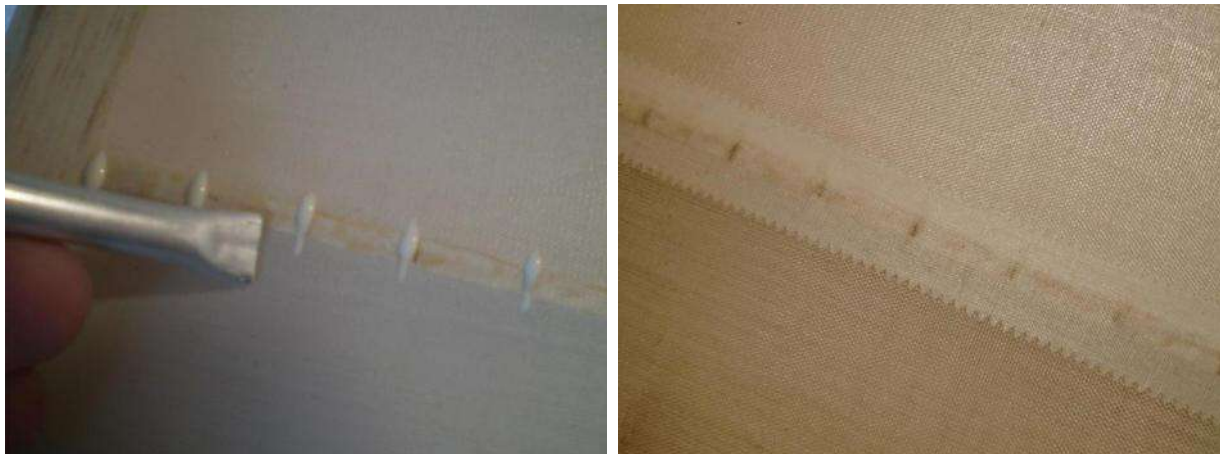

Simulate rib stitches with diluted white glue applied with a pinched 7/32" aluminum tube.

Iron pinked-edge rib tape over the rib stitches. Seal the entire surface with nitrate dope. Sand lightly.

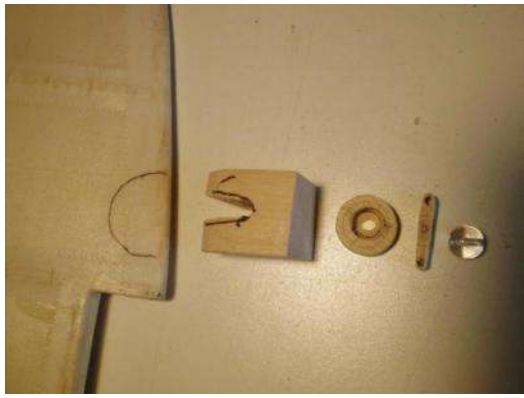

Cut the tail-light parts from balsa and ply. Add small screws and a glass bead.

One-piece Non-removable Stab Assembly

Measure your car. Be sure the fuselage will fit. If not, consider a three-piece plug-in stab (see Stab Assembly). But if the fuselage with a one-piece stab will fit... Omit the twin servos. Mount a 200 in-oz (minimum) servo above the radiator (see Fuselage Assembly). A one-piece stab saves 5 ounces, mostly in the tail.



One-piece stab or three-piece plug-in stab ? Extended Robart Super Hinge Point

A total of 6 Robart Super Hinge Points are required for the elevators. Because the leading edge of the elevator is so thick, the joint of the hinges is located deep within the elevator as shown with a “+” on the plans. This setback requires an extension of the stab portion of each hinge. Cut 6 aluminum tubes (K&S 7/32”, Stock #1112) each 1-1/2” inches long. Use epoxy or Gorilla Glue.

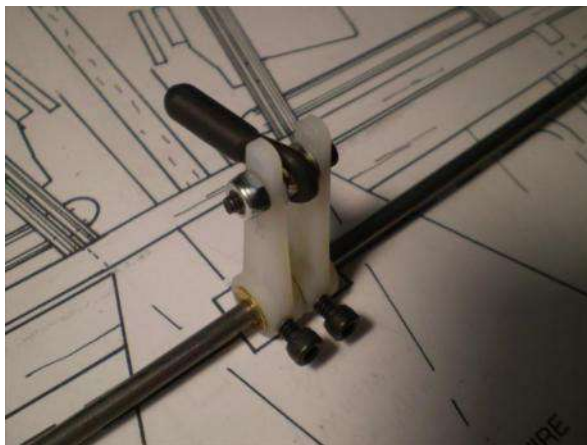

Slide two DU-BRO 5/32” nose gear steering arms onto 5/32” music wire. Bolt a 4-40 ball link between them with washers on either side. Bend the rod ends 6 1/2” apart. Breiten coil bender shown.

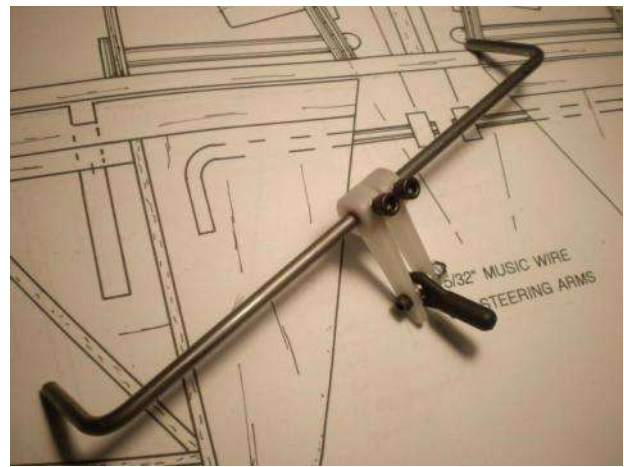
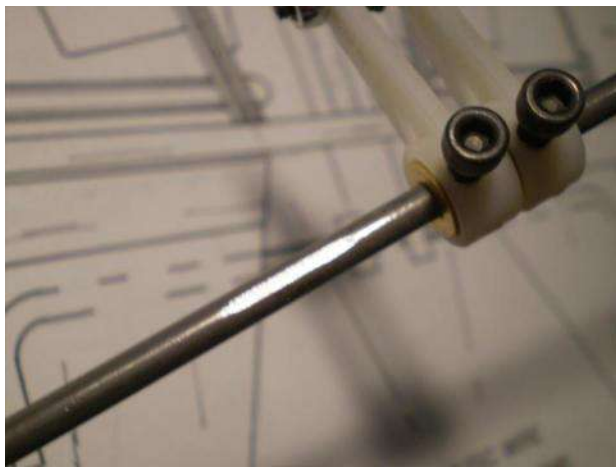

Move the dual steering arms close to the center of the wire. Rotate them so that the arms will tilt slightly forward. This will provide more up-elevator than down elevator plus providing greater clearance ahead of the rudder. File a flat on the wire perpendicular to the set screws in the arms. Move the elevator arms to the center of the rod, apply permanent thread locker and tighten the set screws.

The elevator horn is now ready to install in the elevator. Set it aside for now.

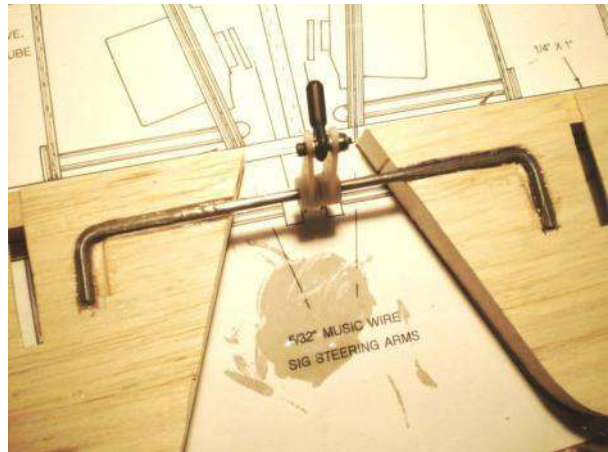

Assemble both elevator halves over the plans. Turn them over and route the groove to fit the elevator horn wire. Epoxy it in place.

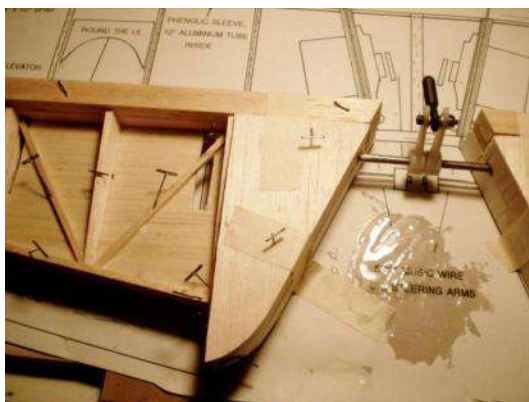

Press the balsa end piece onto the elevator horn wire so that it leaves an impression. Route a groove in the impression. Add epoxy and assemble the bottom halves of the elevators the top halves. Round and shape the elevators with a razor plane and sanding block as shown in Elevator Assembly.



Assemble the stab half over the plans. Omit rib 1b. Cut rib 1a from 1/8" lite ply or hard balsa instead of birch ply. Omit alignment dowels, tubes and sockets. Plane the spars to match the ribs. Add 3/32" sheet shear webs to rib 4, vertical grain, along the main spar.



Sheet the stab with 1/16" sheet balsa. Make two clam shell halves—one will be the upper half and the other will be the lower half. Sheet only one of them at this time.

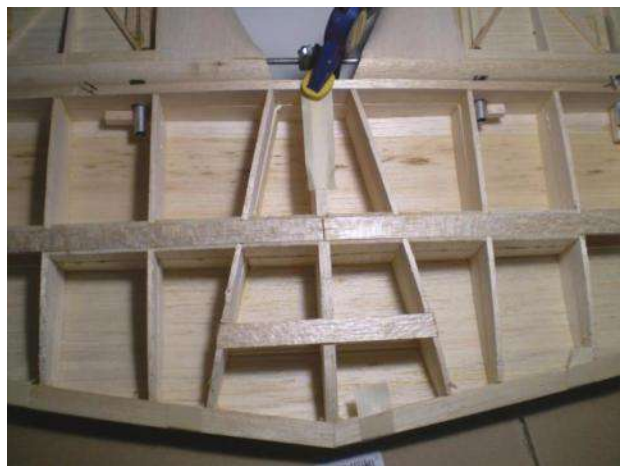

Install the hinges in the elevator. Reinforce. Then epoxy the hinges to the sheeted half of the stab. Reinforce. Glue the as-yet unsheeted other clamshell in place.

Add more hinge reinforcements before sheeting. Add 3/32" shear webs to the main spar, both sides, vertical grain to rib 4 if you didn't install them earlier.

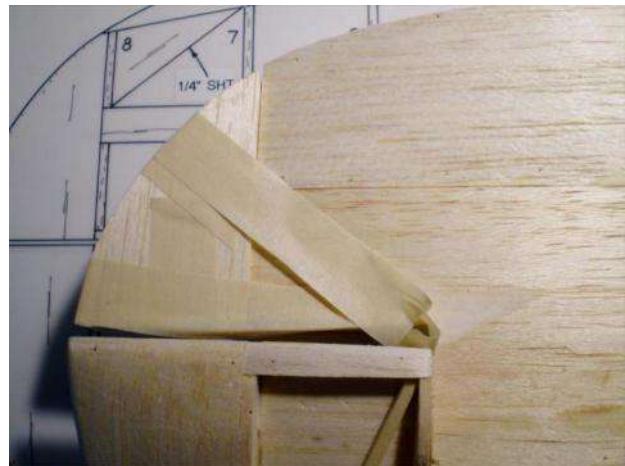

The lower surface can now be sheeted with lightweight 1/16" balsa sheet. Then add the stab tips.

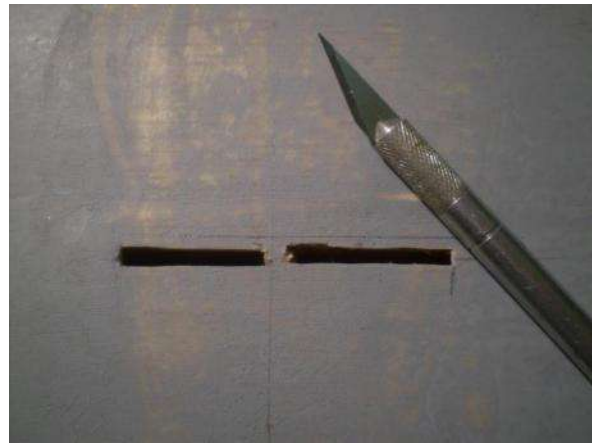

Plane and sand to final shape, ready for covering. Glass and prime the stab before installation. Cut a 1/8" slot in the bottom surface to attach to F22 during installation.



Install a single carbon-fiber pushrod with a single 4-40 titanium or steel threaded end into the ball link between the two steering arms before installation of the stab into the fuselage.

If necessary, splice the pushrod by inserting a 3/32" x 1" brass tube epoxied in place.



If you haven't already done so, cut a notch in the rudder's leading edge for elevator horn clearance.

Removable Stab Assembly

The stab is built in three sections. (Optionally, it can be built in one piece—see the notes on the plans and One-Piece Stab. A one-piece stab saves 5 ounces of weight, mostly in the tail.) The outer sections are removable to allow the fuselage to fit between the front seats of a compact car.

Construction can be simplified and a few ounces of weight saved in the tail if the stab is constructed as one non-removable unit. To do this, build a one-piece stab over the plans, cutting ribs from balsa instead of ply, omitting rib 1b, the guide pins, the aluminum tube and socket. Note that a one-piece stab will not reduce total weight very much because one or two long pushrods will be added.

The following discussion describes the three-piece option but most of it also applies to the one-piece version.

The stab is built as clam-shell halves assembled over the plans. The top half is slightly different than the bottom half. The top half contains guide pins to align the stab. Two pins are included for redundancy and a tighter fit. The aluminum tube is secured in place with field-removable socket-head bolts in the bottom surface.

The lower surface is sheeted last, allowing internal access for reinforcement of the sockets and hinges.

Elevator servos are installed in the outer stab panels. When assembled, the arms, horns and pushrods are hidden inside the center section. By pushing the elevator to fully down position, the horns and arms will fold upward to clear the center section's ribs when the panels are installed or removed.

The elevators will be needed about half way thru the construction process, so it is recommended that they be built first.

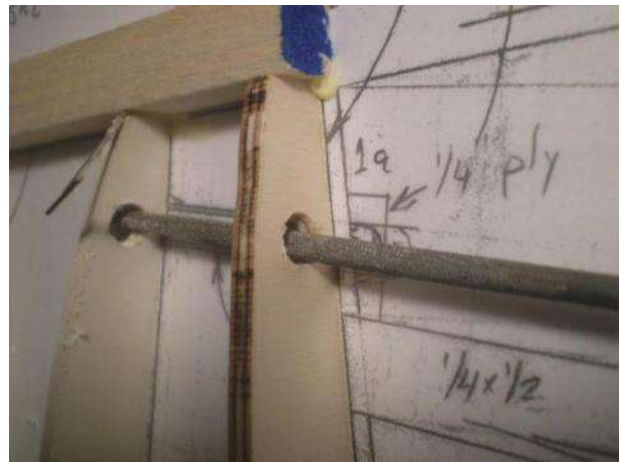
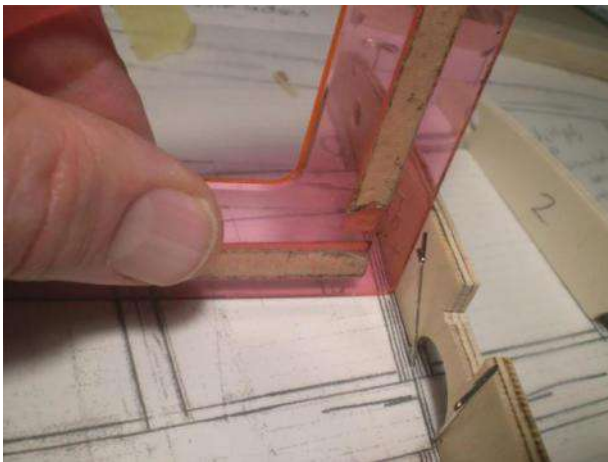

Assemble the top half over the plans. Verify rib 1b is vertical with a draftsman's triangle. File the guide pin hole as needed to fit a 1/4" dowel guide pin.

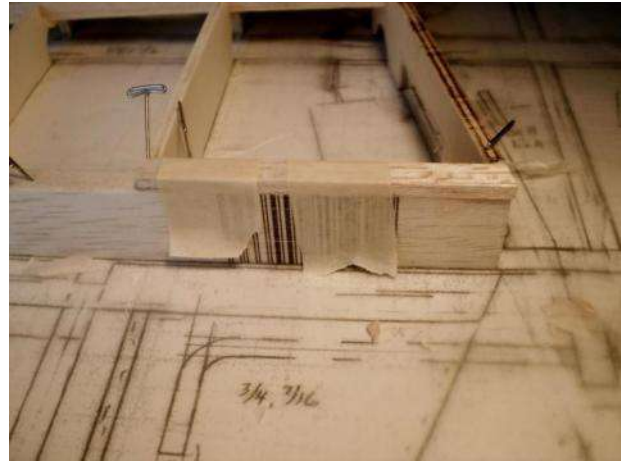
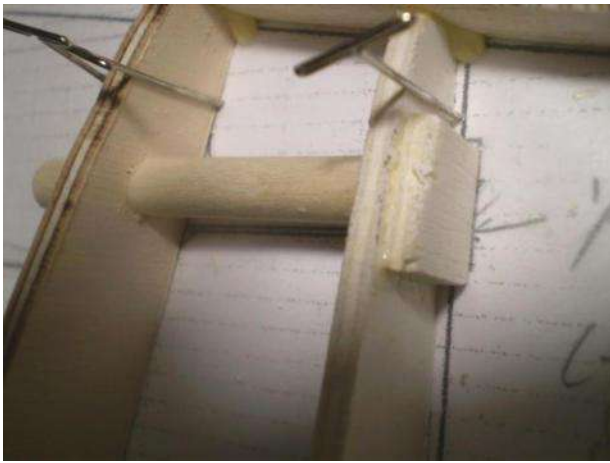

Glue the guide pins in place. Place a cap of lite ply over the pin at rib 2 to prevent the pin from being accidentally pushed inward during field assembly.

The trailing edge at ribs 1 and 2 is not quite tall enough due to the designer trying to not waste wood (or perhaps due to his incompetence) so add a 1/4" x 1/8" scab to the top of the trailing edge here.

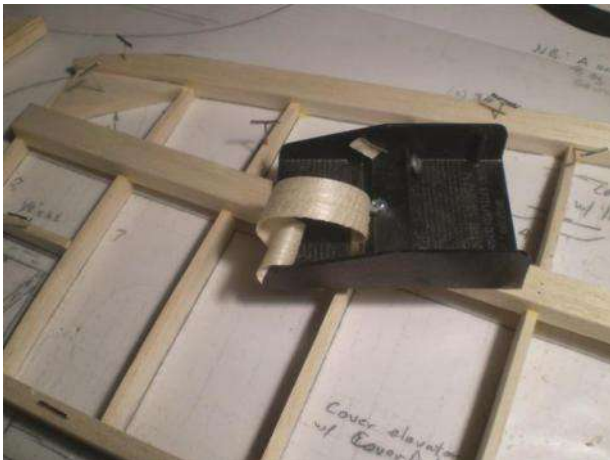

Plane and block-sand the spar, trailing edge and leading edge to match the top of the ribs.

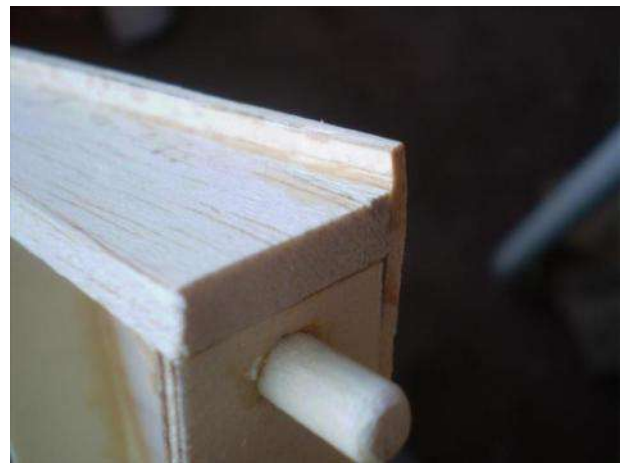
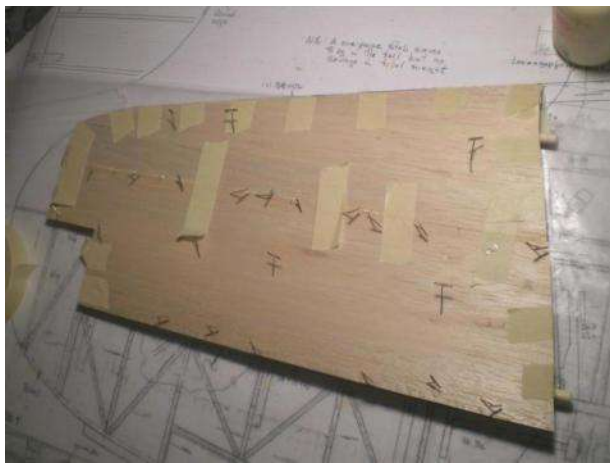

Sheet the top half with 1/16" sheet balsa. Leave 1/8" overhang along the entire trailing edge. Assemble the upper half of the opposite panel. Assemble the lower halves too but don't sheet them at this time.



Assemble the center section over the plans. Sheet only its top surface at this time. Temporarily join the upper halves. Fit the guide pins and fit the phenolic sleeve.

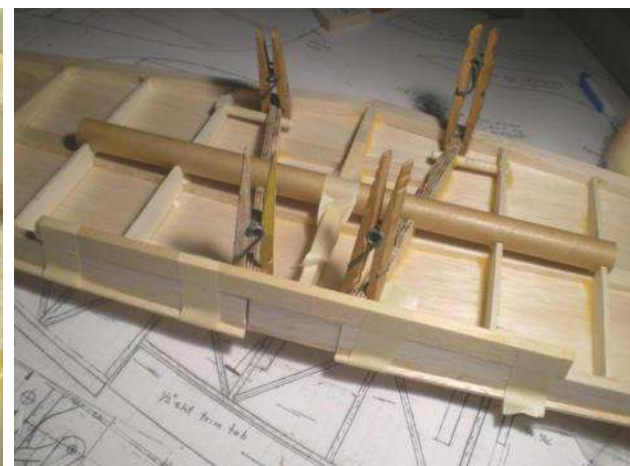

Leave enough space between the ribs for a backless razor saw. X-acto blades will do for spacers. Tape a straight stick to the trailing edge to level the three sections. Spot-glue the sleeve in place.



Cut the tube with a backless razor saw.



Fit, but don't attach the lower half (not yet sheeted).



Add a ply patch to the lower spar where the bolts will be. Position the elevators over the stab's trailing edge spar. Mark the locations of the hinge extensions.

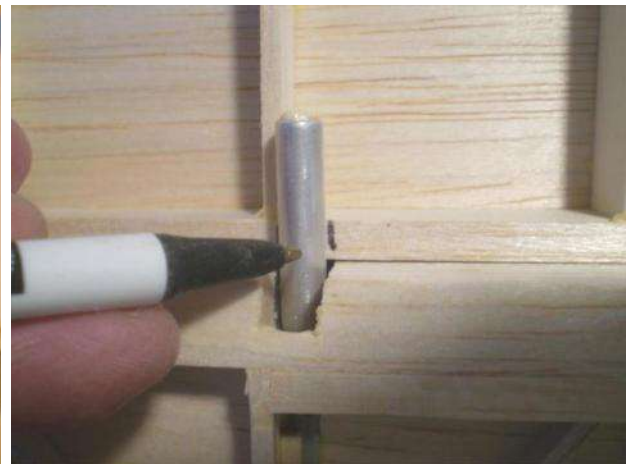

File a half hole at all hinge locations, top and bottom. Glue the upper and lower stab halves together. Add a 1/2" strip of 1/16" sheeting to the trailing edge of the lower half, leaving a 1/8" overhang as was done in the upper half. This will help alignment when fitting the elevators in the next step while leaving the interior accessible.



Fit, but don't glue the elevators to the stab. Remove and attach temporary 1/16" spacers to the stab trailing edge spar.



Epoxy the hinges to the stab while the elevator is pinned in place. Remove the elevators. Remove the spacers. Reinforce the hinges in the stab with 1/2" balsa. Pin in place while Gorilla Glue sets. (It expands to fill gaps.)

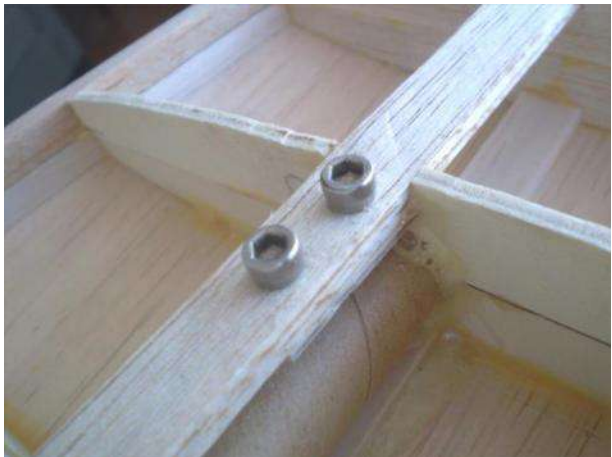
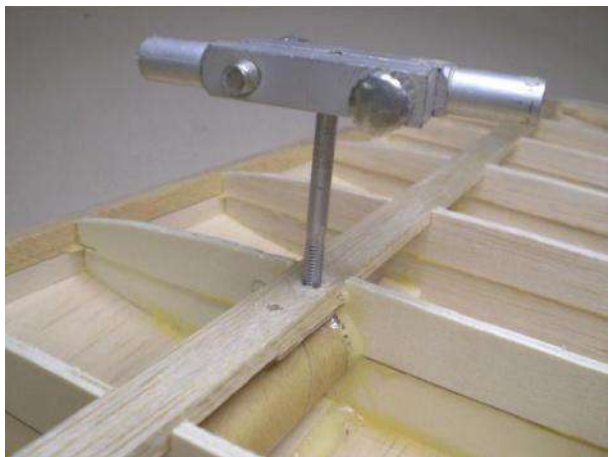

Assemble the center section and both panels with the aluminum tube in place. Drill and tap for two 1/2" x 8-32 socket head bolts in the underside of each panel. (Two are included for safety.)

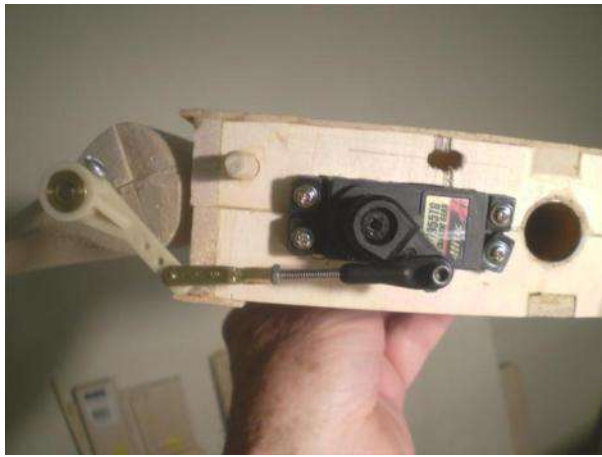

Fit and install the elevator servos. Note how the pushrod and arms retract when the elevator is in the fully down position. This allows the linkage to be hidden inside the center section yet fully accessible for maintenance. Hitech 7955TG servo.

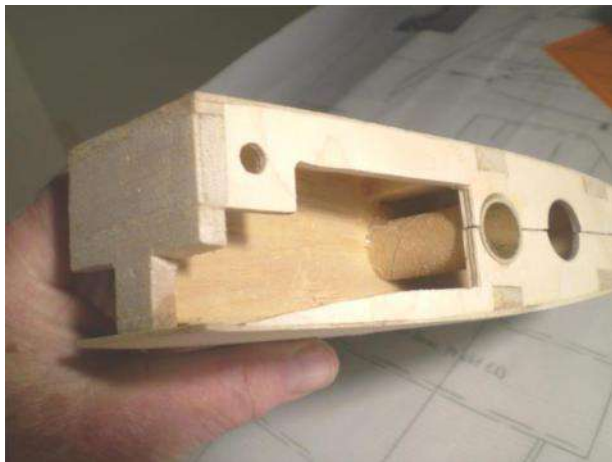

Remove the elevator servo for now. The lower surfaces can now be sheeted. Leave the screw heads exposed but partially countersunk. The stab is now ready for final sanding and covering with fiberglass cloth.

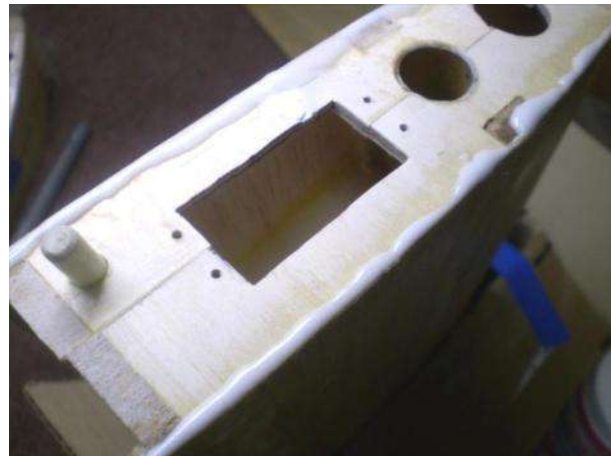

Close the gap between the stab sections by covering the end of one section with Glad Cling Wrap. Mix microballoons and epoxy (or Bondo or any sandable gap-filling adhesive) to a consistency just thick enough to not run. Apply a bead around the edge of its mating section.



Push the two sections together, squishing the sealant. Separate the sections immediately just in case some of the goo got into the alignment pegs or the aluminum tube. Let cure. Peel off the Cling Wrap. If any gap remains (chances are it will). Repeat the process for the other surface.



After the seal has cured, peel away the Saran Wrap. Join the sections and sand away any flashing.



Cut a 1/8" slot in the bottom of the stab behind the spar to accept the tab in F22. The stab is now ready for mating with the fin and fuselage.

Wing Center Section Assembly

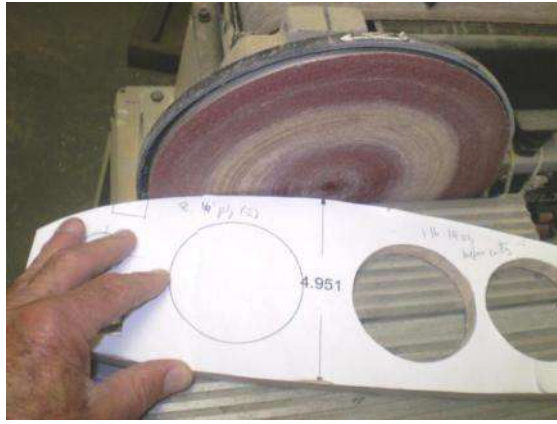
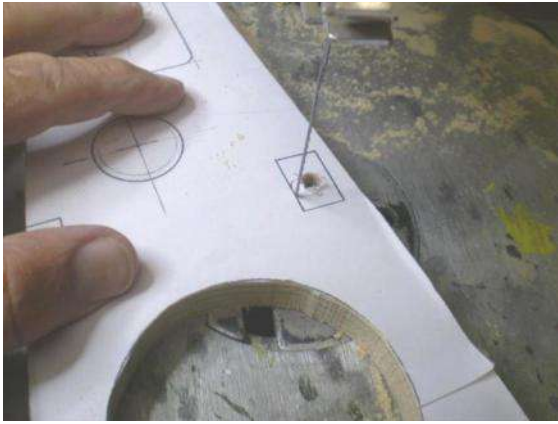

Cut out the ribs using the patterns on the plans. Stack 4 pieces of 1/8" ply and cut out ribs 7 and 8 simultaneously in order to ensure they have exactly the same shape.



Install the flaps servos into ribs 7.

Cut the lower front spar to length. Install blind nuts for the retracts. Note that common hardware store $\frac{3}{4}$ x $\frac{3}{4}$ square "dowels" are slightly less than $\frac{3}{4}$ ". If you use one for the forward spar, adjust the rib notches to the actual size.

Install a rib alignment jig over the plans to elevate the TE of ribs approximately 2 inches. A T made from hardware store $\frac{1}{4}$ " x $1\frac{1}{4}$ " pine molding material will do.

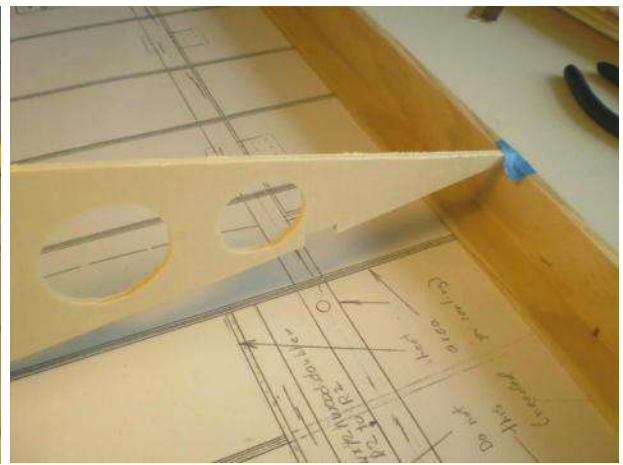
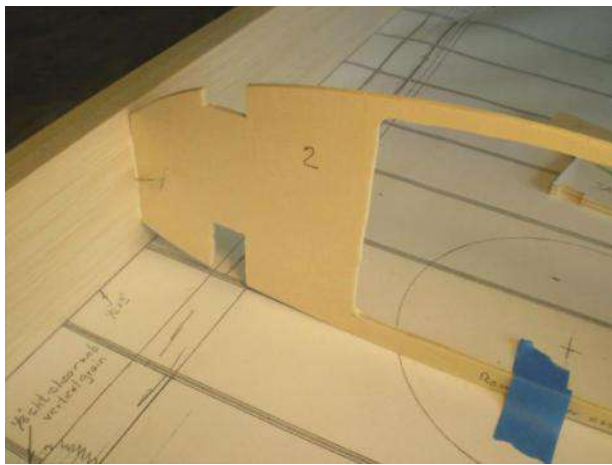

Install $\frac{3}{4}$ x 3 x 36 LE over the plans while the TE of the ribs are supported.



Glue ribs 1 thru 7 in place (rib 8 later) to the LE, upright, over the plans with rib ends elevated approximately 2 inches. Install the upper rib spars.



Turn over. Elevate TE about 2 inches. Remove the temporary section of rib 3. Install the lower spars and fit one retract.



Clamp a straight stick to rib 8 to remove any warp. Install rib 8 with epoxy. Snug it against the retract. Pin or tape in place. Remove the retract before the epoxy sets. Clean any epoxy residue off the retract.



Bevel the rear retract support to clear sheeting. Drill holes in the rear spar for the rear retract support. Install blind nuts under the rear spar. Repeat the above process for the other retract.

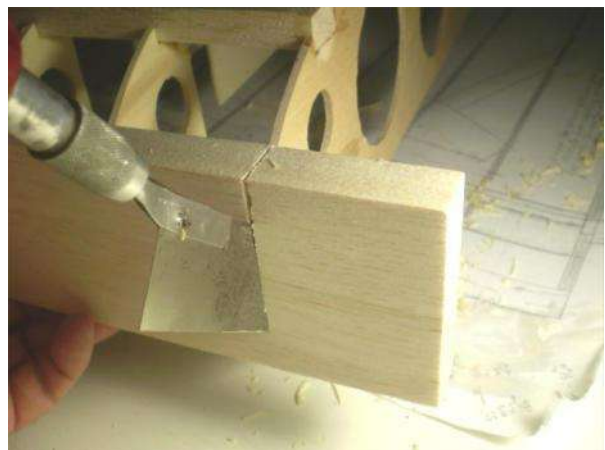
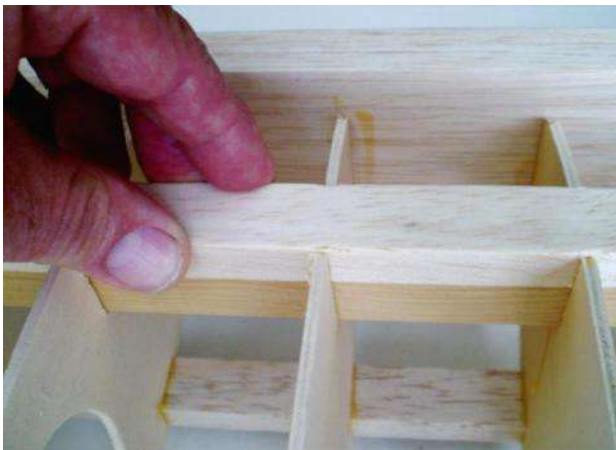

Fill the gaps in the ribs below the lower spars with balsa sticks. Use scrap left over from cutting the other balsa spars to length. This provides bonding for the sheeting. Trim LE and other balsa spars flush with rib 8.



The center section is now ready for mating to outer panels. Lay the center section aside for a while and assemble the outer panels without sheeting but including the wing tubes.

Meanwhile, select either Mick Reeves or Robart 6-inch Hurricane/Spitfire wheels. They are the same size and weight but Reeves wheels are more scale and have no non-scale lettering molded into the tires. (Why do they do that!)



Install the wing sockets with the outer panels in place and elevated to the dihedral angle shown on the plans. The socket holes in ribs 5 thru 7 are $1/16$ " larger than the socket holes in rib 8. This allows space for alignment of the sockets during assembly. Let the sockets extend slightly beyond rib 8 and leave a small gap between the panels so that epoxy won't get on the aluminum tubes. Epoxy well, rotating the sockets in order to get epoxy into the joints. When cured, remove the outer panels. Fill remaining gaps with epoxy and sand the sockets flush with rib 8. Plane the LE and upper rib spars to match the rib contours.



Assemble the inner flaps (See Flap Assembly). Install the flaps and flap linkage. Allow for 90° deflection as per full-sized. Note that the full-sized Hurricane used 90° deflection on landing. But this required full up-elevator to flair. Roy Vaillencourt (see References) recommends only 30° deflection with power on and not attempting 3-point landings.

Install the 1/8" sheet hard balsa shear webs. They are important for strength and flutter prevention.

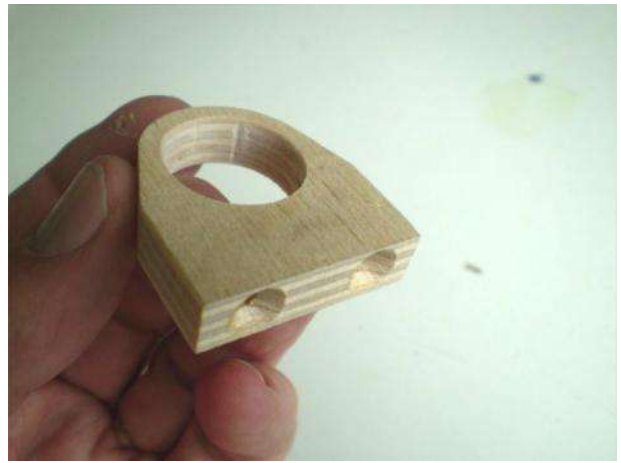

Drill and countersink holes for #6 x 1/2" wood screws in the bottom of the door guides before cutting out the door guides with a scroll saw. Sand the hole for a loose fit around the upper oleo strut, so that the door will ride up and down with the axle.



Cut a pedestal for the Sierra Giant Scale 3/4" strut collars from 3/8" ply. Counter sink for 6-32 x 1/2" FH machine screws. Cut the counter sinks slightly oversized so that 1/32" sheet aluminum will be drawn into the holes. A diameter of 1/16" larger than the screw heads is about right. Apply epoxy to the bottoms of the guide and clamp pedestals when attaching them to the doors.

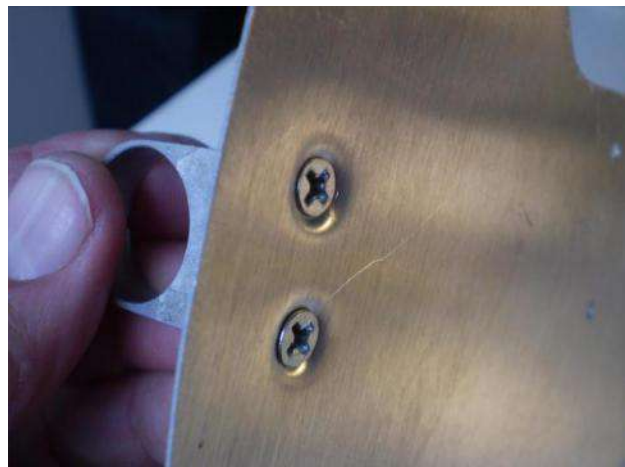
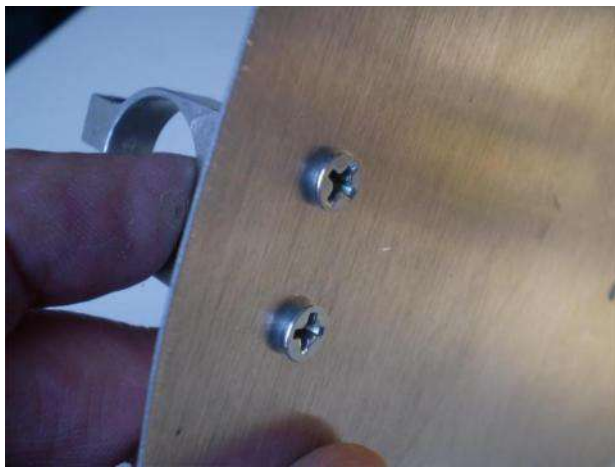

Attach the guides and clamps to the 1/32" aluminum doors with 6-32 x 1/2" flat-head machine screws. The aluminum will be drawn into the counter sink as the screws are tightened.

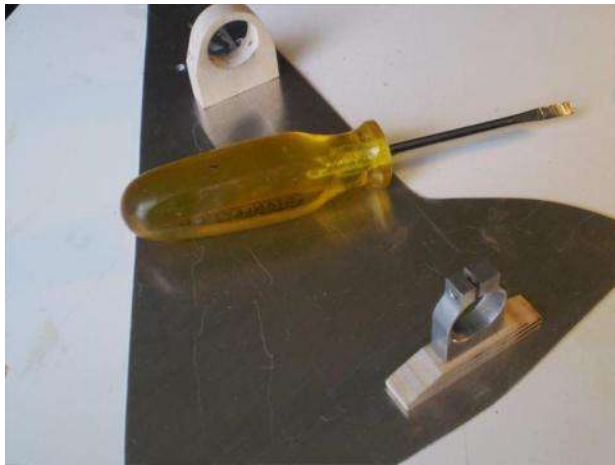

The doors may now be fitted to the retracts already installed in the wing. Temporarily place a piece of 1/8" sheet balsa near the doors to simulate sheeting. The doors should rest slightly above the balsa surface, not in it, to avoid the risk of jamming. Trim or shim the clamp and guides where they meet the door surface if necessary. After fitting to the wing, putty (Bondo) may be applied over the screw heads and sanded smooth.

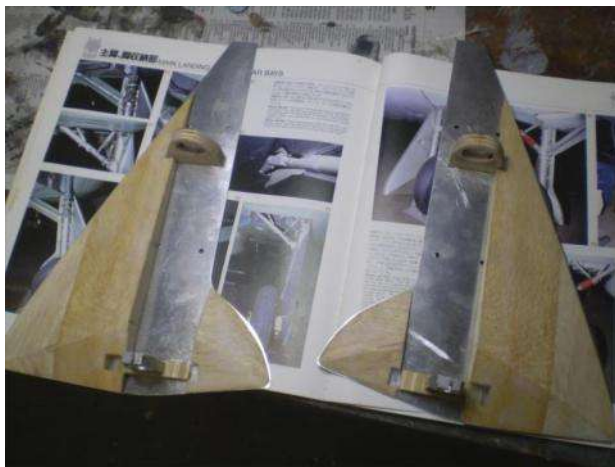

Shape and fit balsa fairings to doors using photos as a guide. Glass and primer the fairings before gluing them to the doors.

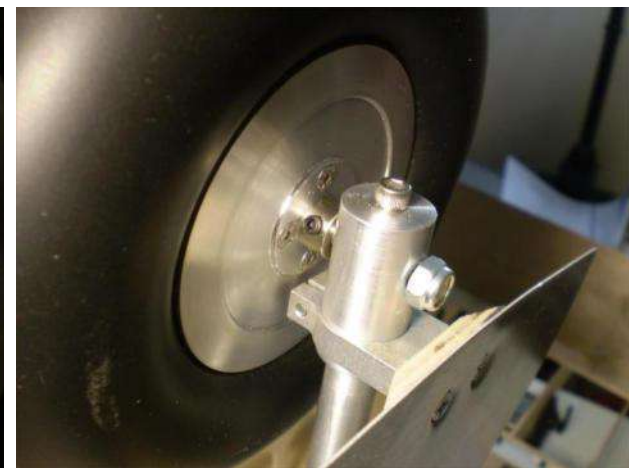

The wheel and axle are held in place by the bolt head on the end of the axle, an 8-32 x 1/2" set-screw in the end of the strut and a 10-24 stop-nut on the end of the axle. A 1/4" DU-BRO wheel collar (set screw not needed) provides clearance between the wheel hub and the door clamp. Apply grease to the bearing.

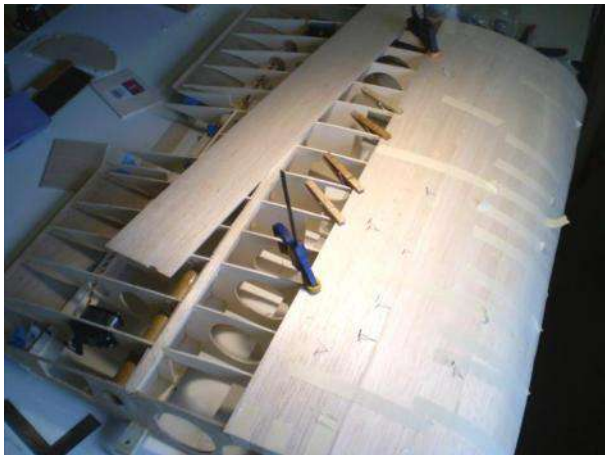

Fit the landing gear to the wing before sheeting the wing.
Turn over, support with lower surface alignment jig and sheet the upper surface
Attach the center section to the fuselage (see Fuselage Assembly).

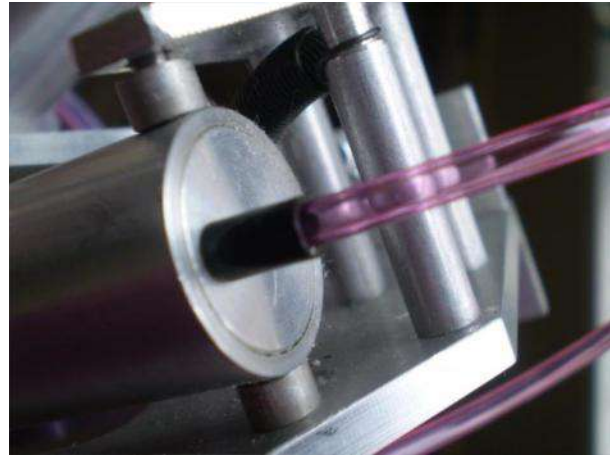
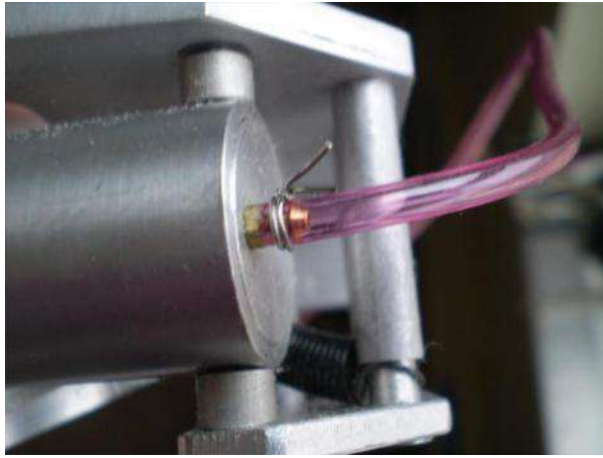

Attach air line tubing to the retracts before final installation. Secure the connections with either double-wrap soft wire clamps or Tom Cook plastic tubing clamps (recommended).



Install a balsa strip to the lower inner edge of the outer rib to increase sheeting gluing area. Add a 90° balsa wedgy (not shown on plans) to support the lower sheeting in this area.



Spot-glue aileron and flap servo extension wires in the outer wing panels. Complete the sheeting of the lower surface. It must be flat where the oil cooler intake will be attached. Cut the wheel wells using the doors and wheels as a guide.

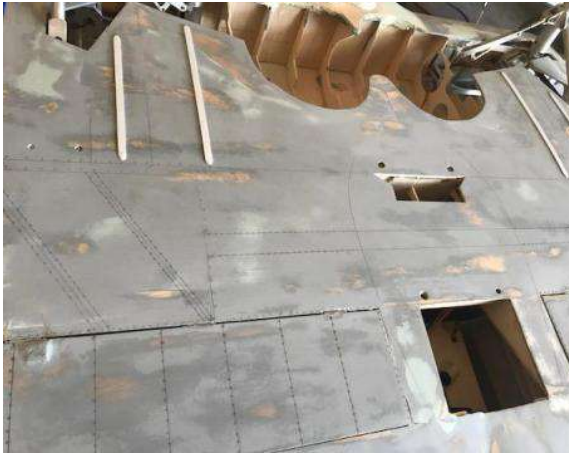

Add reinforcing strips.



When completed, the result should look like this.

Outer Wing Panel Assembly Procedure

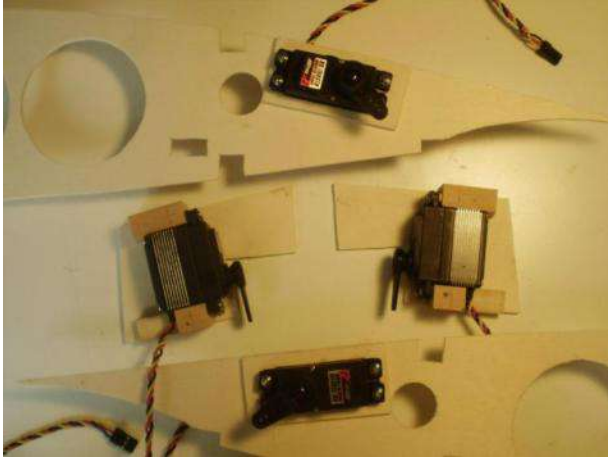

First, install the flap servos. If Spangenberg servo links (shown) are to be used, install the aileron servos now too. File wing tube holes in ribs 8-11 for a snug fit.

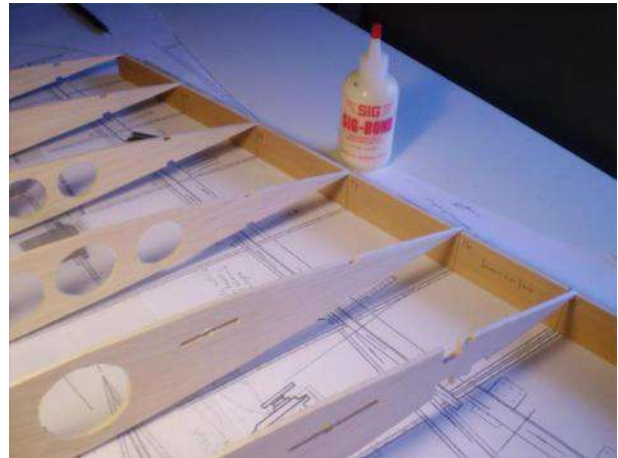
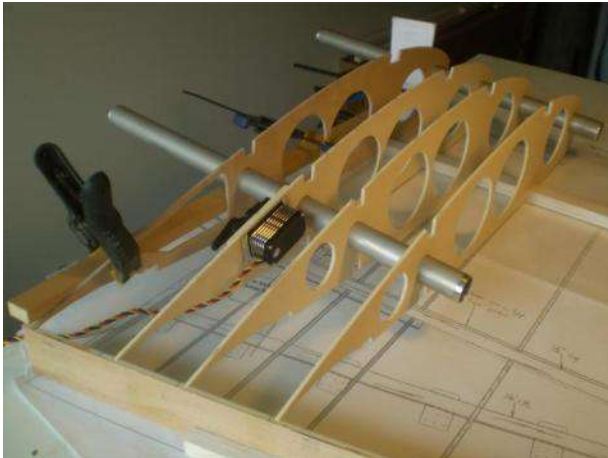

Lay the lower main spar flat on the plans. Install ribs 8-11 upright on the wing tubes and place them on the plans, elevating the TE with the lower surface washout stick. Spot-glue a couple of them to the washout stick. Verify a loose but snug fit of the tubes. Don't glue them in place yet.

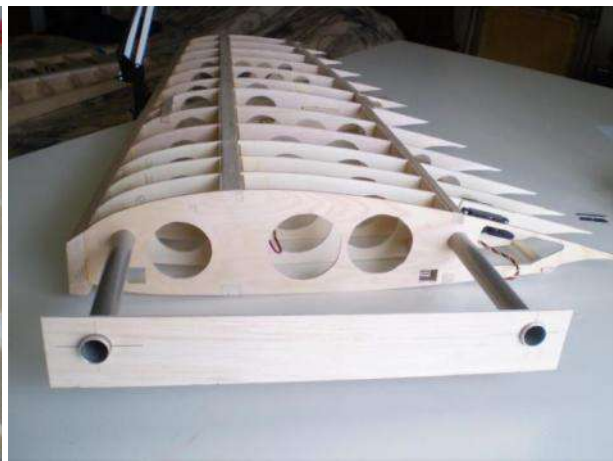
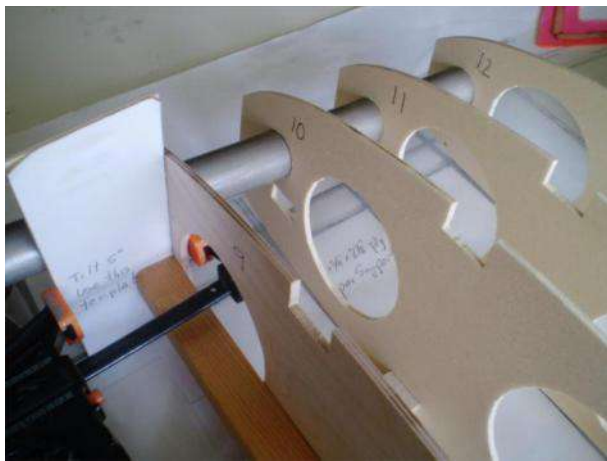

Clamp a straight stick to rib 8 to remove all warps and make it straight. Tilt Rib 8 five degrees using the tilt template shown on the plans. Make a jig having two 7/8" diameter holes spaced apart the same distance as the tube holes in Rib 8 (13 3/4 inches). Apply it to the end of the tubes to verify that the tubes are parallel. Enlarge the holes in ribs 8-11 if necessary so that the jig fits the ends of the tubes. Don't glue the tubes yet.

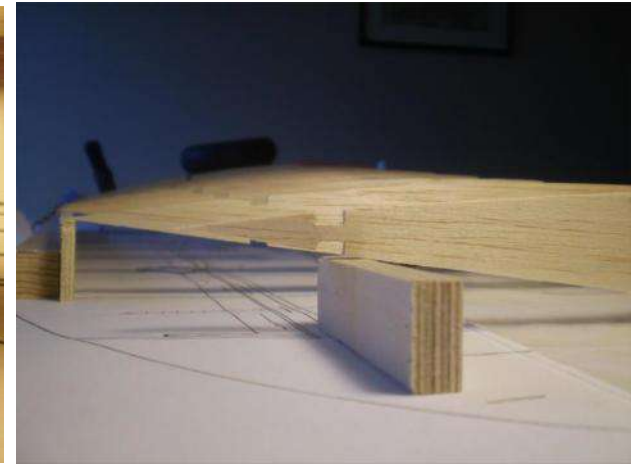
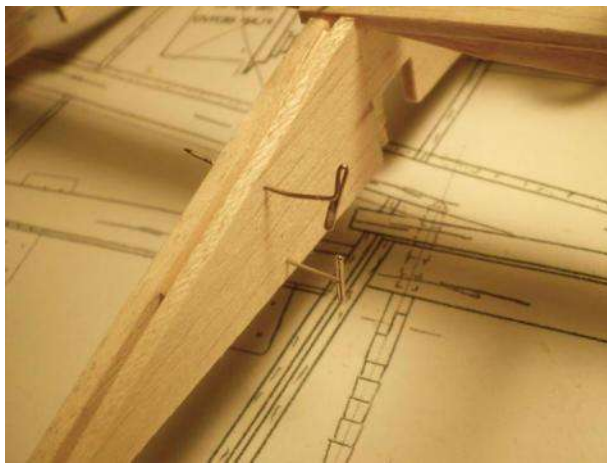

Glue the other ribs to the lower mains spar. Pin sub rib 15 to rib 15 with a 1/16" spacer. It will become the inner rib of the aileron. Elevate the end rib 21 so that it aligns with rib 20.

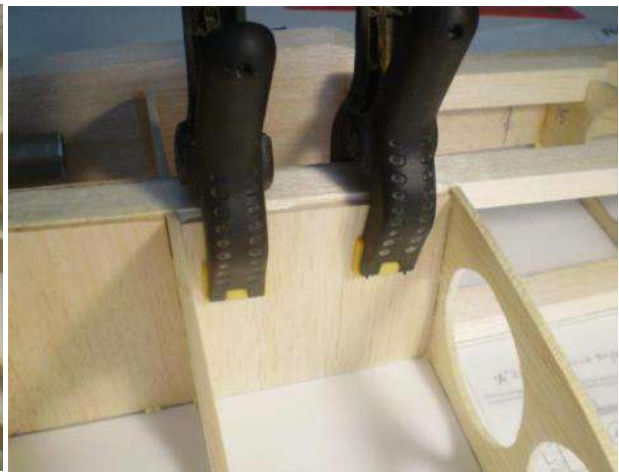
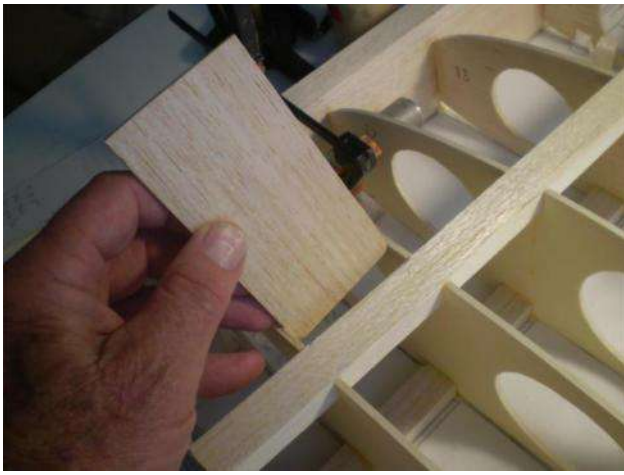

Glue the upper spars in place. Install sheer webs in the main box spar. Vertical grain. The sheer webs increase the strength of the box spar and they also make the wing twist-resistant, increasing the flutter speed. This is a lot of work but it is pleasant work and very important. Do a good job.

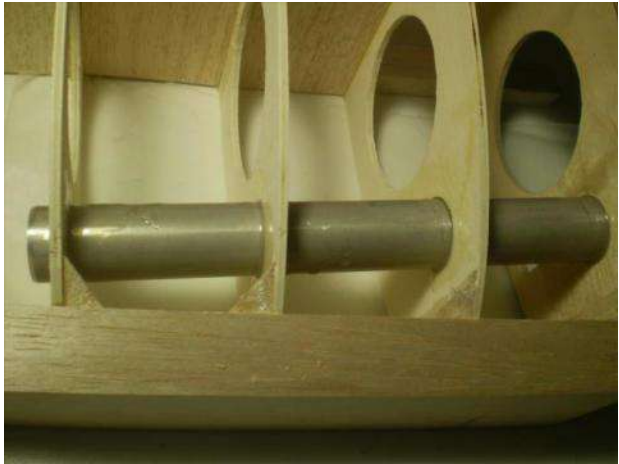
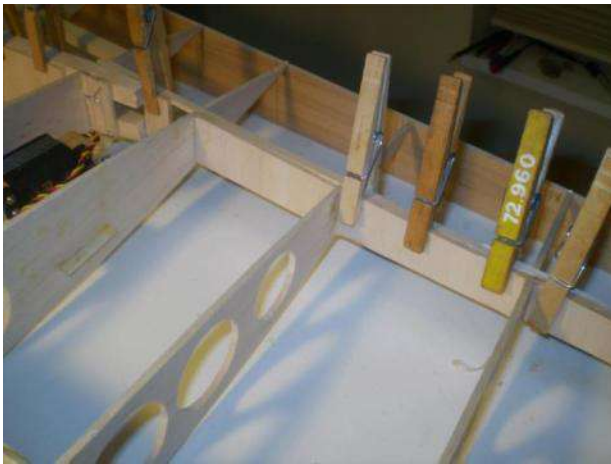

Install sheer webs in the rear spar but not next to the tube area in ribs 8-11 yet. This makes the wing rigid so we can at last glue the wing tubes in place using lots of slow-set epoxy. Apply the tube jig again to the tube ends to assure that the tubes are parallel while the epoxy sets.



Wing ready to receive sheer webs next to the rear wing tube. Note how the flap servo is accessible thru the large opening in rib 9.



Clamp the as-yet unshaped LE to the bench. This allows easy access to the aileron hinge line. Add balsa hinge supports on the wing side of the aileron hinge line. Use scraps left over from trimming the spars.



Lay $\frac{1}{2}$ " sheet balsa beside the aileron ribs and mark the length and width of each section between the ribs. Cut the sections to length and fill the LE area of the aileron with the $\frac{1}{2}$ " balsa. Leave a $\frac{1}{32}$ " gap using temporary spacers. Coffee shop wooden stirring sticks work well. The gap leaves room for a razor saw to cut the ailerons free in a later step.

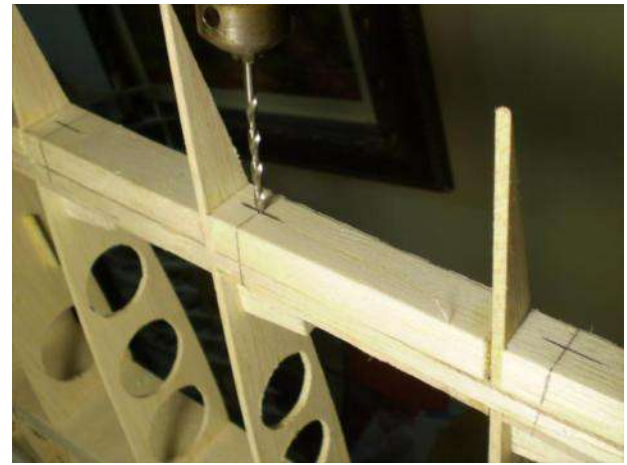
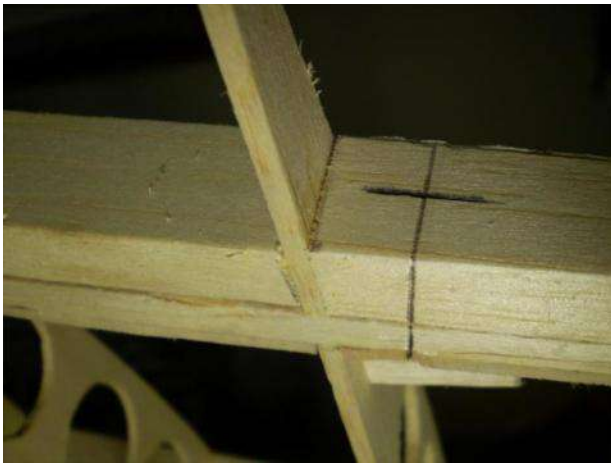

Mark the location and angle of each Robart hinge position. Drill a 1/8" pilot hole thru the aileron leading edge and the hinge supports in the wing. The pilot hole will be used later to extend the holes for the Robart hinges. Plane the supports flush with the ribs.

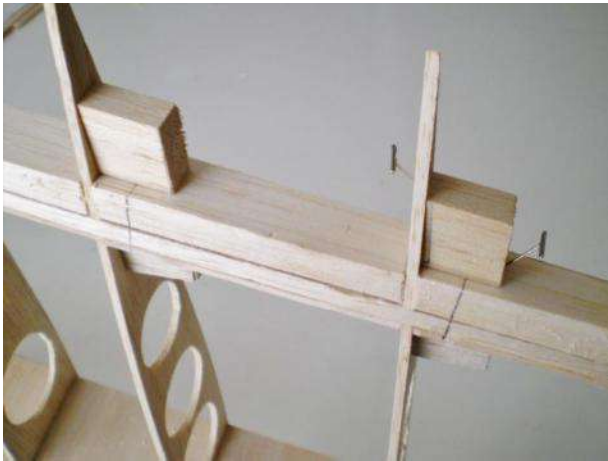

Add 1/2" hinge support blocks behind the aileron LE.

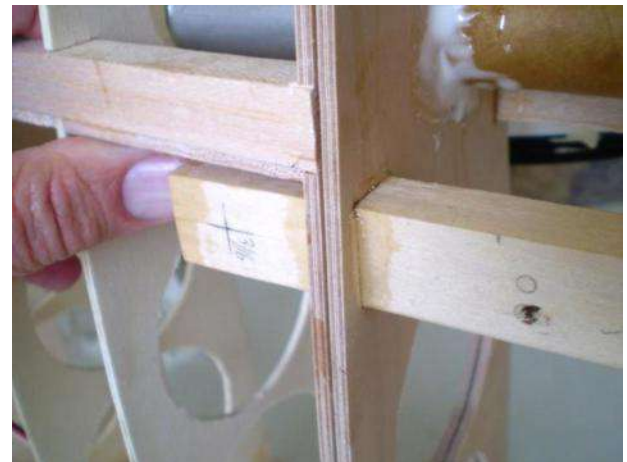

Trim the sockets and spar of of the ends of the main and outer panels flush with the end ribs. Assemble and verify that the lower main spars fit into the holes in rib 9. Enlarge the holes if necessary.



Use the rib 8 tilt template again to bevel the (4) wing bolt supports by 5 °. Slip them into the wing thru the hole in rib 8 and epoxy in place.

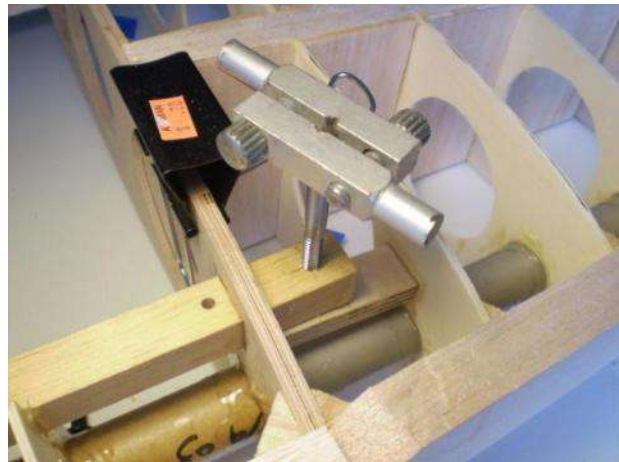

Reinforce the front wing bolt support/ rib 9 glue joint with a 1/2" a flat-head screw, slightly off center to clear the (soon to be installed) wing bolt. Assemble the inner and outer panels again. Clamp their end ribs (ribs 8 and 9) together. Drill and tap the spar ends and wing bolt supports for 1/4 x 20 plastic wing bolts.

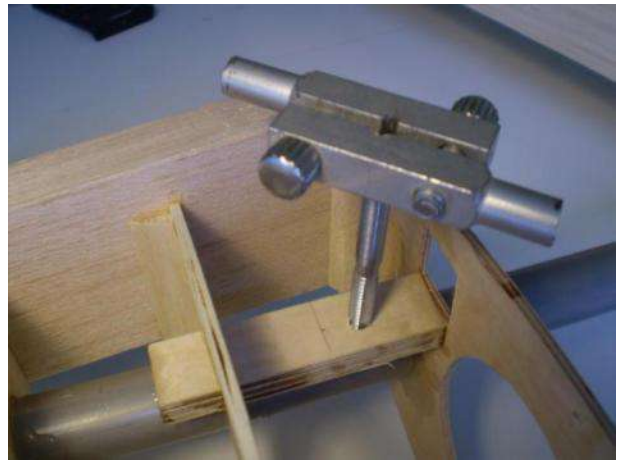
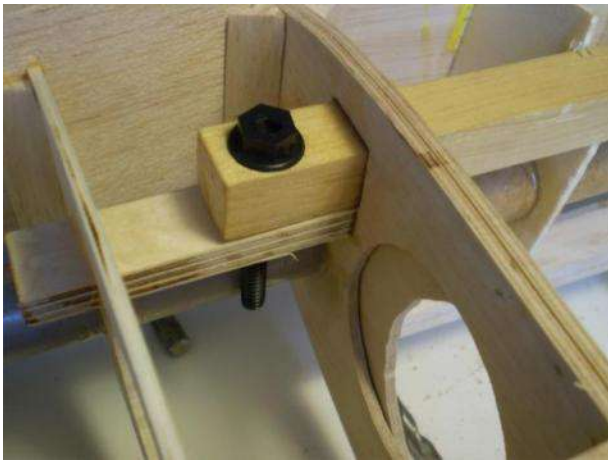

Trial-fit the wing bolts. Remove and separate the wing panels. Harden the threads in the wing bolt supports with thin CA glue. When cured, “chase” the threads with the tap again to remove the fuzz in the threads.



Secure each rear wing bolt support with a small flat-head wood screw.

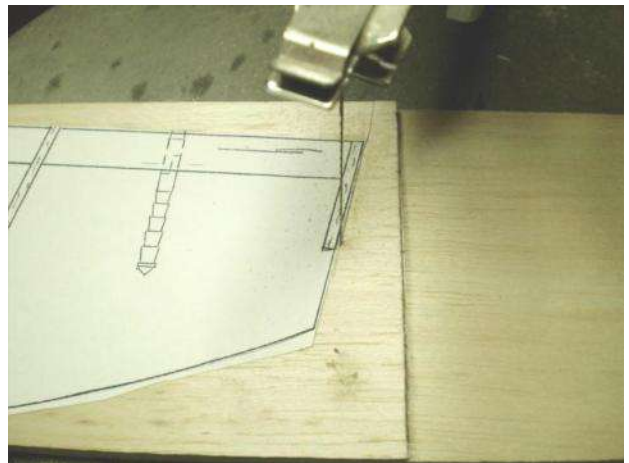
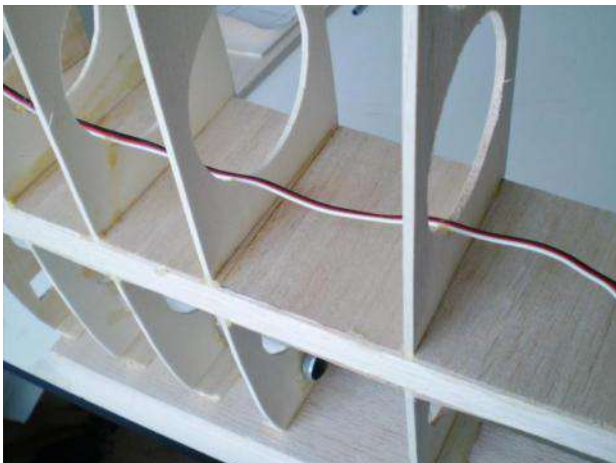

Tack-glue the aileron servo cable to the ribs to prevent it from wearing in flight. Stack 4 sheets of 1/8” balsa and cut the aileron skins.

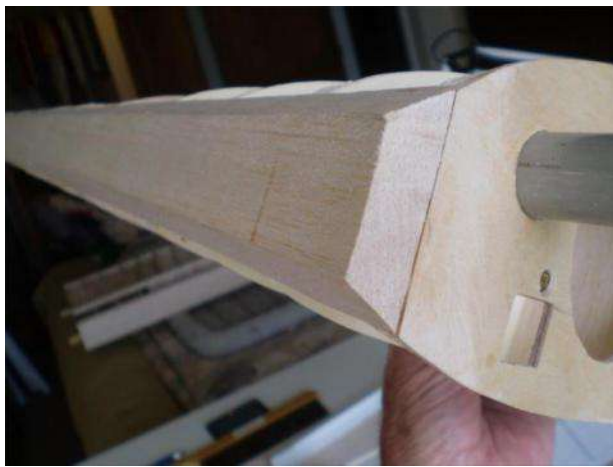

Bevel the leading edge in preparation for sheeting. Plane all the other spars flush with the ribs. Assemble the aileron hinges. Extend the length of the Robart sockets by epoxying them into 2-inch long $\frac{1}{4}$ " diameter aluminum tubes. Sockets allow the ailerons to be removable during and after assembly.



Bevel the rear $\frac{3}{4}$ " of the inside surface of an aileron skin and glue the aileron skin in place. When dry, glue the other aileron skin in place

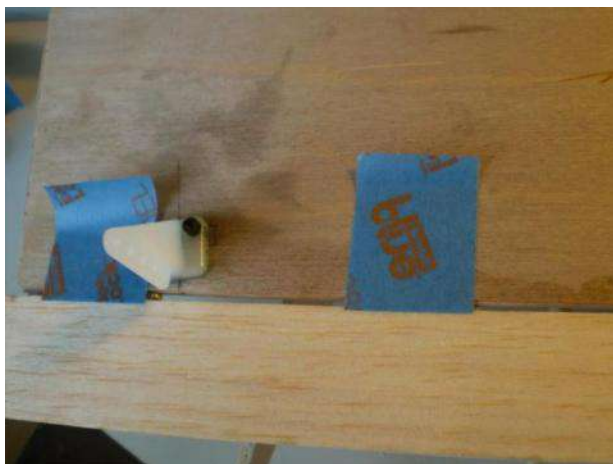

Assemble the flaps (see Flap Assembly). Cover the inside of the flap hinges to protect the hinge pins and glue the flaps in place. Cut the ailerons free with a backless razor saw.

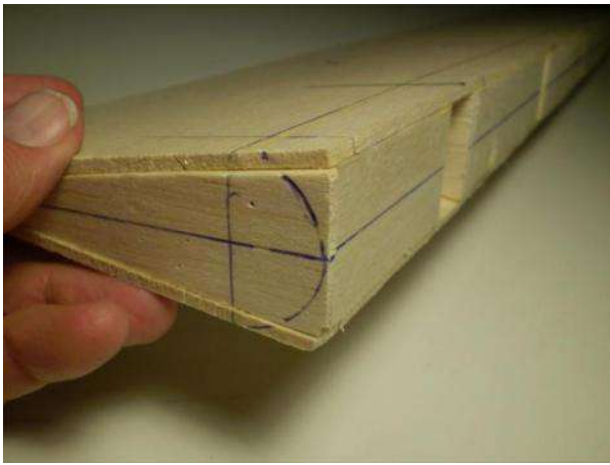

Mark the hinge lines and the radius of curvature on aileron and shape the leading edge with a razor plane and a sanding block. Drill holes for the Robart hinges and shape the opening to allow the hinge to swing $\pm 45^\circ$. Glue the hinges in place with epoxy or Gorilla Glue.

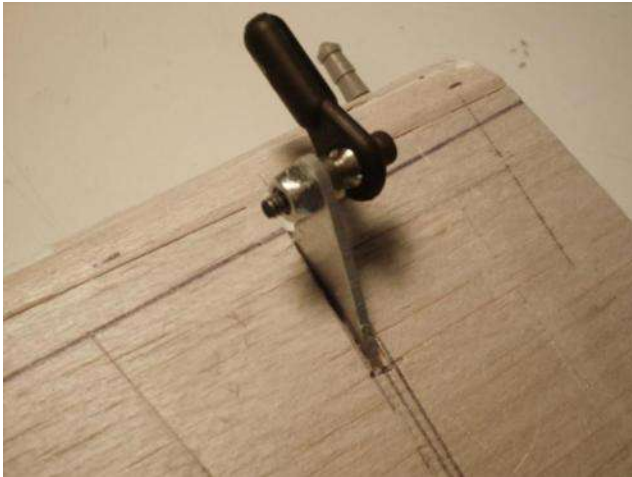

Cut away a rectangle of sheeting from the lower surface of the aileron. Install the aileron horn supported with balsa blocks and epoxy. Then replace the sheeting.



Enlarge the holes in the wing TE and trial-fit the ailerons in place. Adjust the holes if necessary for a bind-free fit. Glue the hinge extensions in place with epoxy or Gorilla Glue. The ailerons can be removed by loosening the set screws in the hinge pockets.



The wing panels are now ready for sheeting. Elevate the TE of an inverted wing panel with the top surface washout stick and verify the washout angle by taping straight sticks to the end ribs. Sight along them to verify that the washout angle is $3\frac{1}{2}$ degrees. Then sheet the bottom surface.

Turn over, set the panel upright on the bottom surface washout stick. Verify the washout angle again. Sheet the top surface. Plane and sand the surfaces flush with the ailerons.

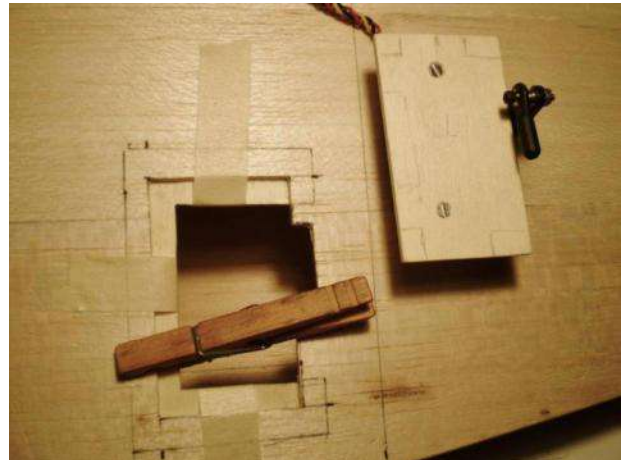

Mate the outer panel to the inner panel again. Trim and shim the junction with balsa sheet. Remaining small gaps will be filled later after glassing. Install the aileron servo tray support in place.



Cut LE for landing lights, both panels. Reflector is half ping-pong ball painted with silver Krylon.



Cover the wing with 1.2 oz fiberglass cloth. Apply one coat of Klass Kote gray epoxy primer with a mini-roller. Fill low spots with Bondo. Knock down the high spots with 150 grit sandpaper in a palm sander (10 x faster than hand-sanding). Repeat if necessary.

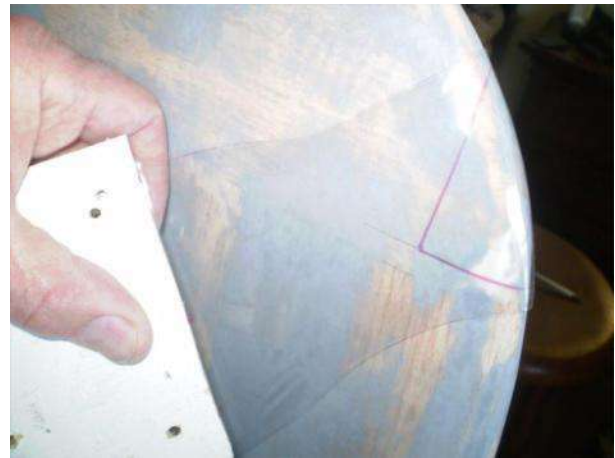

Poor man's vacuum-forming: Mark the outlines of the nav lights in each wingtip. Clamp a 4" x 7" piece of PVC or other clear plastic between 4" x 4" x 1/4" ply handles. Heat the plastic over a kitchen stove burner until it sags. Quickly stretch the plastic over the landing light area and let it cool. Trim the plastic, cut away the marked area in the wingtip, add interior detail and install the nav light cover. Repeat for the nav light in the other wingtip.



Cover the end of the center section with Saran Wrap to prevent sticking. Apply auto body filler or epoxy & microballoons to the end of the outer panel. Join panels while standing on end. After it sets, pull apart and remove the Saran Wrap. Repeat for other side. Trim flash. This provides a seamless and hardened intersection between the wing panels.

Surface Details



Rivet plates are vinyl stickers from Callie Graphics. Simulated Dzus fasteners.



Rivets and panel lines on wing tips.

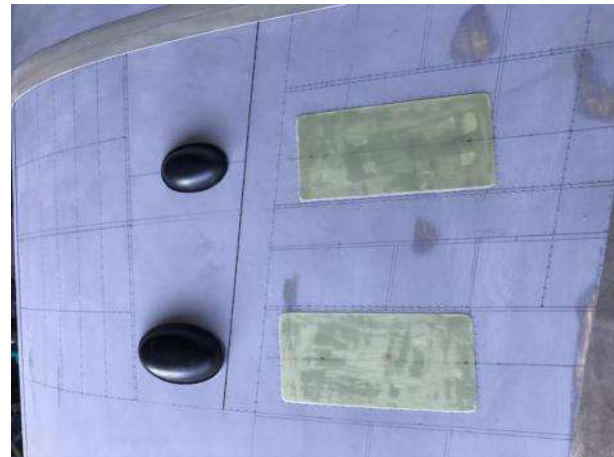

Breech blisters and ammo doors.



Add scale reinforcement strips and rivets on the bottom of the wing.





Draw invasion stripe with a carpenter's laser. Mask per laser line and spray.



Attach Kirk Schneider gun shrouds and barrels. Compare to full-size.



Two-tone or one-tone bottom color scheme.

Wingtip light.

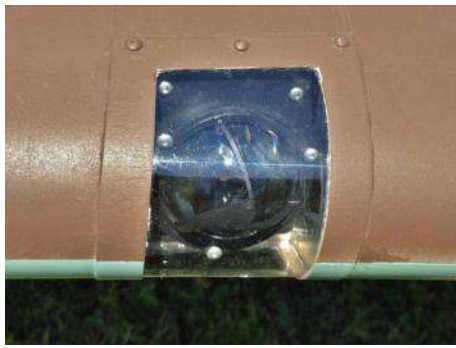

Kirk Schneider landing light



Wing joint cover is G10



First flight, Jeff Quesenberry, July 6, 2018, Owatonna Minnesota

Weight 51 lbs Nose weight 6 pounds

Dual inline Quadra 54s, 24 x 12 Zinger propeller

First flight video at

https://www.youtube.com/watch?v=CTIF5F_6FLs&feature=youtu.be

Control Surface Throws

The following control surface maximum deflections were used in the prototypes:

Elevator $\frac{3}{4}$ inch up, $\frac{1}{2}$ inch down.

Set ailerons 1 inch up and $\frac{3}{4}$ down. Then 60% of that.

Rudder all you can get

Flaps at 35 degrees

References

This design is derived from the Koku Fan Hawker Hurricane drawing, catalog number KF 4516.

Copies are available from Aircraft Documentation Services, <http://www.airdoc.biz>.

The plans were drawn by enlarging the following sections of the Koku Fan drawings and filling in the structure.

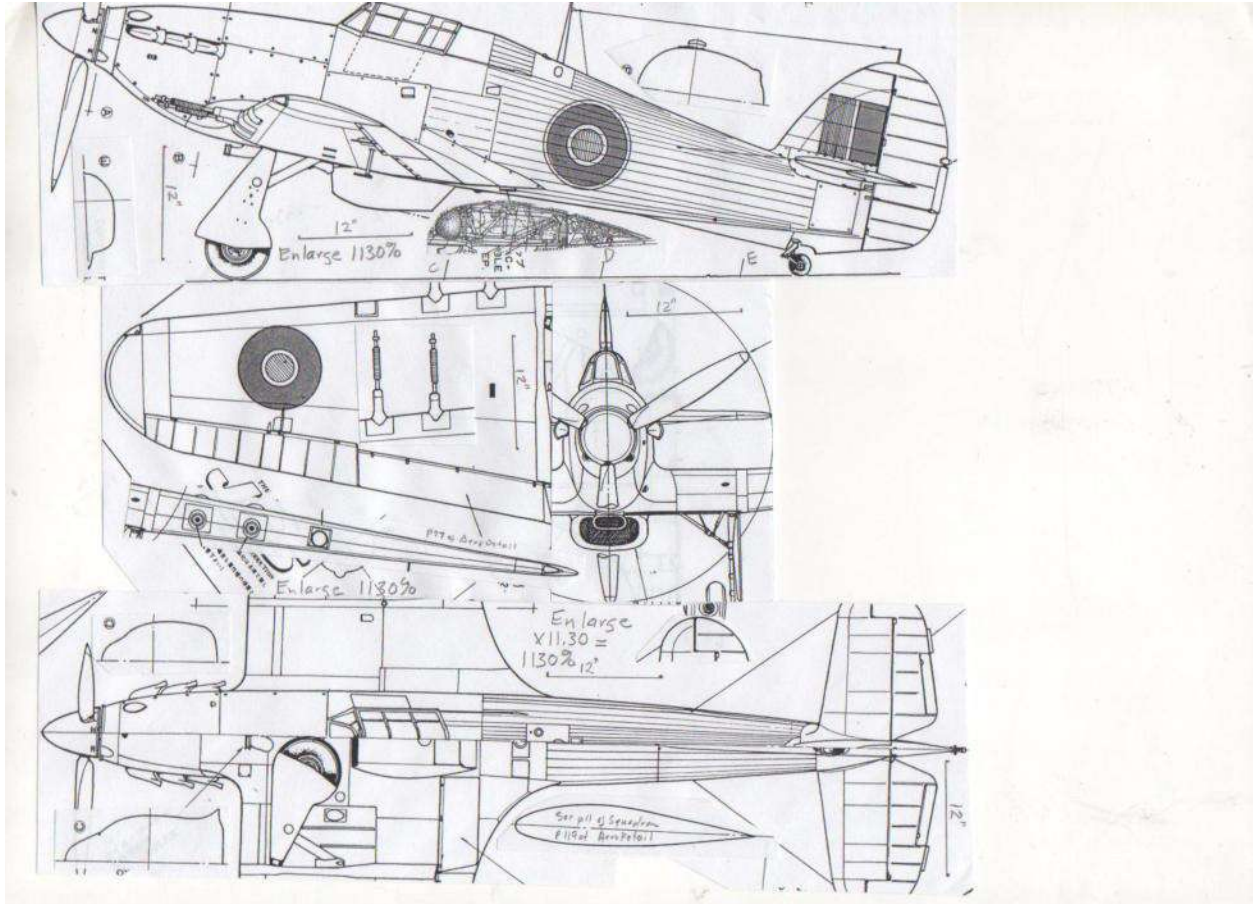

Deviations from the Koku Fan drawings include the following:

--The wheel size (24-inches full size) was adjusted per measurements taken of the full-size Hurricane in the Canadian Warplane Heritage Museum by Tony Paladino.

--The airfoil was derived from the Willis Nye drawings because the Nye airfoil better matched the photos.

For proof-of-outline in formal competition, the Koku Fan drawing KF 4516 is recommended.

Details not included in the Koku Fan drawing were derived from photos in these publications:

Hurricane in Action, Squadron/Signal Publications No. 72.



Aero Detail 12, Hawker Hurricane, RZM Imports, Dist.,

Available from <http://www.rzm.com/books/model/aero.cfm>

Also of interest:

Landing techniques re Roy Vailencourt's 4.5 scale Hurricane:

<http://www.vaillyaviation.com/images/Hurricane%20landing%20technique.pdf>



<https://doogsmodels.com/2016/05/24/review-132-fly-hawker-hurricane-mk-ii-c/>

<http://www.rcuniverse.com/forum/rc-warbirds-warplanes-200/11620728-dave-andersen-1-4-scale-hawker-hurricane-2.html>

<http://www.militaryaviationmuseum.org>. Virginia Beach, VA, (757) 721-7767

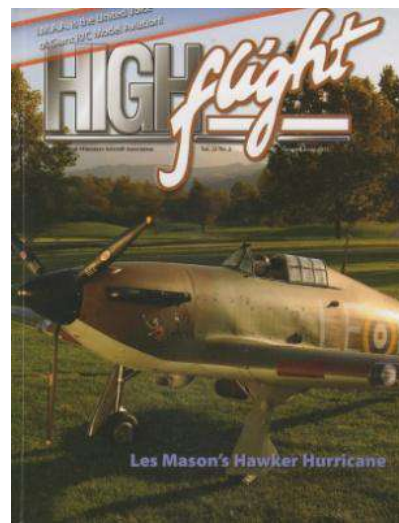
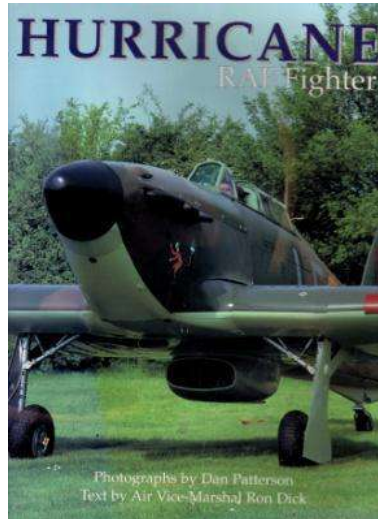
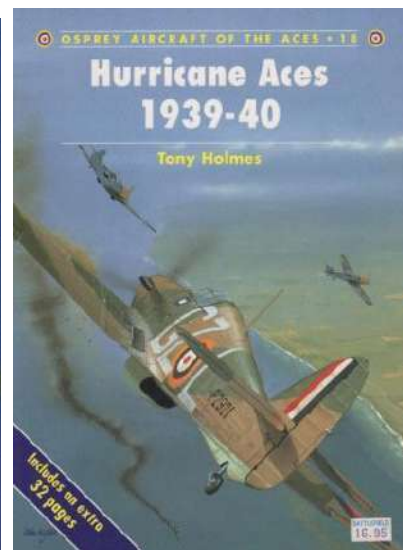
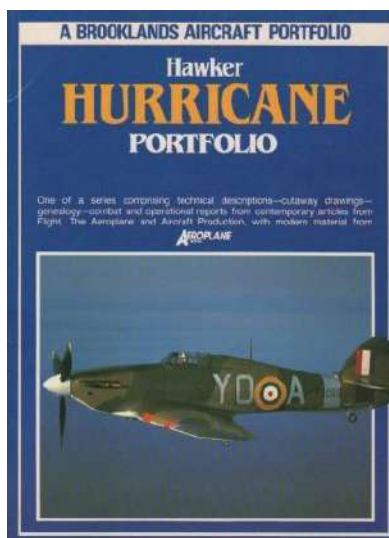
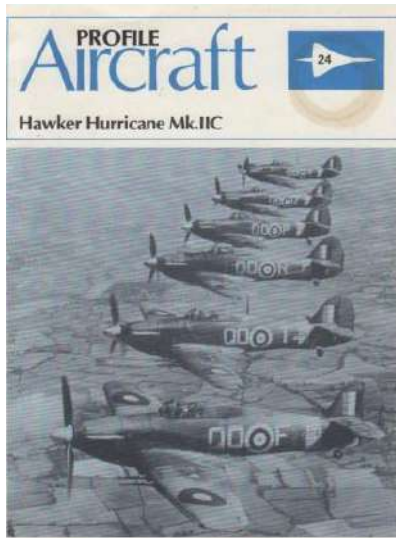

Walk Around Photos by Permission of RCScaleBuilder.com

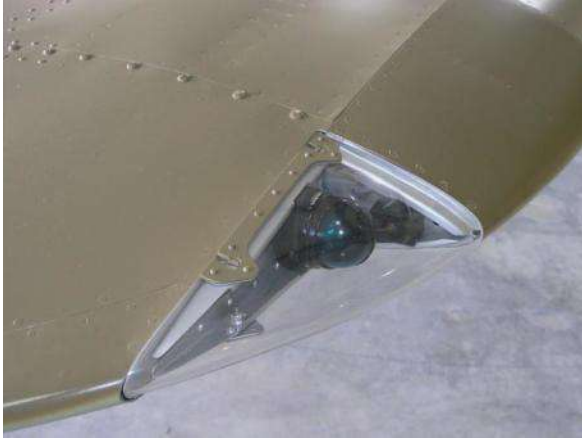









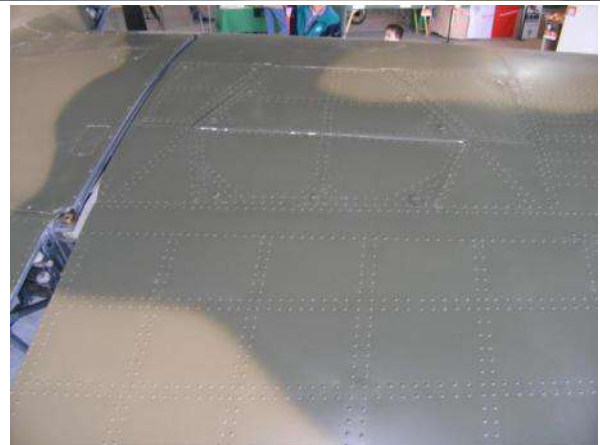







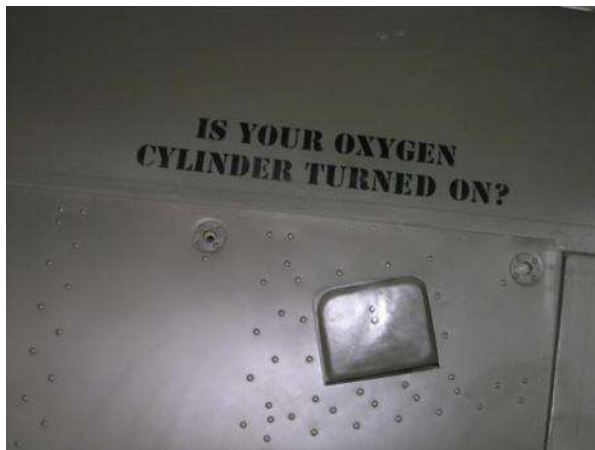

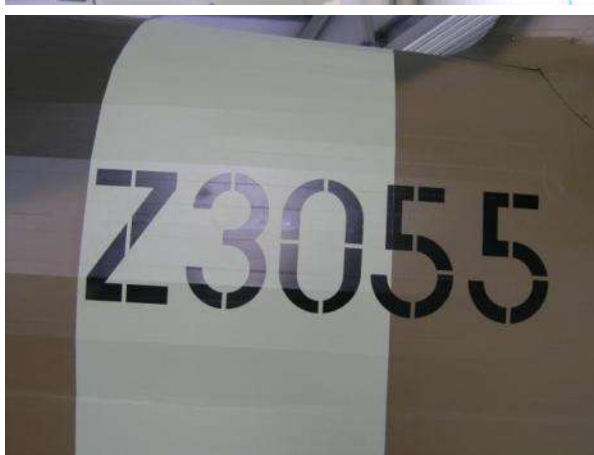

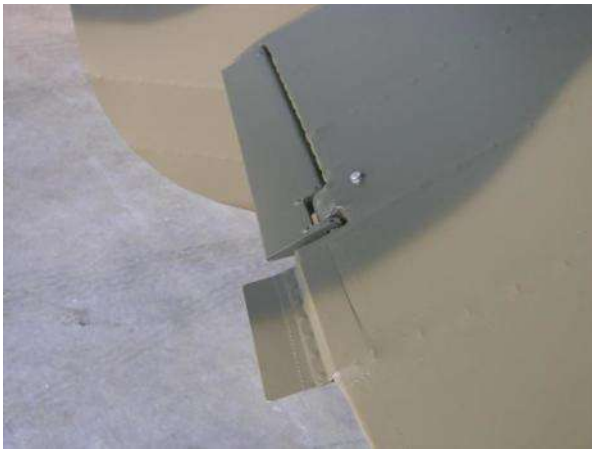

A brief history of the Hawker Hurricane IIA



The name of the Hurricane will forever be linked with the Battle of Britain, in which, with its partner the Spitfire, it added one of the most glorious chapters in the annals of the Royal Air Force. During that fateful engagement of 1940, Hurricane pilots shot down more enemy aircraft than all other defences, air on ground, combined. Later the Hurricane added its laurels to the defence of Malta, in the Western Desert and in Burma; indeed no other Allied aircraft ever fought in as many theatres as did the Hurricane.

The project began life as a private venture, intended to meet the requirements of Specification F.36/34, issued in early 1935. The

first prototype, K5083, was ordered on 21st February 1935, and made its maiden flight in the hands of Group Captain PWS Bulman on 6 November that year. The Hurricane, as it came to be named, was a winner from the start, and in June the Hawker Board of Directors decided to prepare for production of 1,000 aircraft on their own authority. This action galvanised the Air Ministry into action and in very short time an official contract for 600 Hurricanes was placed.

The first production Hurricane was flown on 12th October 1937. The first Hurricanes in service had two-blade fixed-pitch propellers. This was soon improved by the substitution of a de Havilland two-position three-blade metal propeller and, in 1939, the excellent Rotol constant-speed propeller.

The Hawker-type fuselage, which had featured in all, Hart variants and Furies since the 1920s, was retained in the Hurricane in preference to modern but complicated metal fuselage, in order to speed production of Hurricanes. By August 1940, the height of the Battle of Britain, a total of 2,309 Hurricanes had been delivered and 32 squadrons equipped, as against 19 Spitfire squadrons. At the outbreak of the war, Hurricanes were chosen to accompany the RAF bomber squadrons to France. The first enemy aircraft shot down by RAF fighters on the Western Front was by a Hurricane. The type was also involved in the desperate fighting in Norway.

On 2nd August 1940 Hurricanes of No.261 Squadron were flown off the carrier H.M.S. Argus to relieve the hard pressed Sea Gladiators in the defence of Malta against attacks by the Italian Air Force. These were among the first Hurricanes to operate in

the Mediterranean theatre, and joined a handful of Hurricanes which had been flown out to Malta from Britain the previous month via France and North Africa.

No account of the Hurricane would be complete without reference to the work of the Merchant Ship Fighter Unit which, in 1941, helped to protect vital convoys in the Atlantic from attacks by the enemy maritime bombers. These Hurricanes, mostly time expired machines, were equipped to be catapulted from the decks of merchant ships and the pilot later parachuting into the freezing sea to await rescue.

In the late 1944 the 12,711th and final Hurricane built in Britain (there were also over 1,400 built in Canada) was completed.

Z3055, the eight gun Hurricane IIA of No.46 Squadron, exhibited (under construction) at the Malta Aviation Museum, took off from Safi strip just before daybreak on 4th July 1941. For some unknown reason (thought to be engine fire), the pilot, Sgt Thomas Hackston, crashed into the sea and was killed. The Merlin XX powered aircraft, one of forty-two Hurricanes delivered to Malta (Operation Backer) had flown off the carrier H.M.S. Ark Royal, barely a month earlier. One of the 5th production batch of 1,000 aircraft built at Kingston the aircraft was delivered from the factory to 48 Maintenance Unit at Hemenden on 27th February 1941 and prepared for squadron service. It was transferred to Abbotinch the following month but only stayed until it was transferred to 5 Maintenance Unit at Kenble. It was delivered back to Abbotinch on 18th May, for shipment to Malta and taken on charge in Malta (126 Squadron) in July 1941.