

“Ahead of,” or “in front of”

The Avanti is a .60 powered full pattern ship for the advanced Sunday Flyer.

By Donald A. Grassi

avanti



Avanti” translated means “ahead of,” or “in front of.” I’m not quite sure just what this creation is ahead of or in front of, but the name seemed to have a nice ring to it, so “Avanti” it is.

The design presented here is the result of a four year labor of love that started with a compulsive desire for a good looking “groovy” model that I could call my own, capable of doing the full pattern, with good low speed landing characteristics. The “Avanti,” which is the fourth in a series, has, in fact, turned out to be all these things and it is with great satisfaction that I dedicate this article to the ‘Sunday Flier.’

At the outset, many of the then current designs were studied both on paper and at the flying field. The “Kwik Fli” was chosen as the point of departure, consequently the first version in the series was a modification of the “Kwik Fli,” but as the design evolved the similarities all but disappeared.

The original versions had rectangular wing planforms which, ultimately, evolved into the current tapered wing. While the rectangular planform was more forgiving in the round maneuvers, such as loops and Figure Eights, the tapered wing reacts better in the rolling maneuvers. Besides, the tapered wing just plain looks



A delightfully lively bird that goes through its maneuvers in a manner that can best be described as graceful. It can be flown slowly without falling out of the sky and, conversely, will climb vertically until practically out of sight.



compartment, installing the firewall bulkhead, the motor mounts, the landing gear mounts, and other high stress locations. On all other balsa to hardwood, or balsa to plywood joints I use white glue. On all balsa to balsa joints I use Ambroid (double glued) with the only exception being gluing up the fuse doublers to the fuse sides where contact cement works quicker.

A flat working surface is mandatory. One that works quite satisfactorily and is relatively stable can be made by contact cementing together two pieces of 3/4" x 18" x 48" particle board which is available at your local lumber yard.

WING

To obtain a "true" tapered wing the best results are obtained by using a wing jig, or as I prefer, a dihedral board that permits building both wing panels simultaneously. However, for those who have neither a jig nor the building space required for the one piece construction, the following procedure will provide very satisfactory results.

Tape one of the wing panel plans to your work surface, the right one first if you're North of the equator, and the left one first if you're South of the equator.

Start construction by cutting out two each of all ribs to the outlines shown, sanding them in pairs. While both R1's are still clamped together jig drill two 1/4" diameter holes (as shown) through both of them, preferably on a drill press. These will be used later for accurately joining the wing panels. Make one each of the jig blocks shown on Ribs R2, 5, 8, and 11, from 1/4" or thicker balsa. The bases of these jig blocks should be square with the sides. Pin them down firmly, centered under their respective

better. The earlier versions had a symmetrical airfoil of 18% constant chord to thickness ratio. The present design uses a symmetrical progressive airfoil, 17% thickness at the wing root and 18.5% at the tips, which enhances the wing tip stalling characteristics. No, that doesn't mean the tips stall better — it means they stall last! The wing is set up with 1/16" positive incidence, the engine with 1 1/2 degree downthrust. This setup, coupled with the progressive airfoil, makes possible truly low speed approaches with a minimum of attention required on the elevator, and landings that flare out beautifully.

CONSTRUCTION

Before getting into the details of construction, several comments are in order. All four versions of this design were covered with silk and dope and weighed in at 6 1/4 to 6 1/2 lbs. when new. As each of the previous versions grew older and heavier with successive repair jobs (due mostly to running out of air and the inevitable sudden stops)

each became less responsive and generally more difficult to handle on low speed approaches.

The most recent version weighs 100 oz. (6 1/4 lbs.) which seems to be ideal, so keep it light. If you plan to cover with one of the heat shrink materials you can build a little heavier, but if you plan to silk and dope, select your balsa carefully. Use soft balsa blocks and planks and medium/soft on all sheets. The use of hard balsa should be restricted to the wing spars and leading and trailing edges, to the fuse keel and stringers, and a few other selected places, as noted on the plans.

Regarding the non-controversial science of gluing, I'd like to say that while I'm not a member of the cult that goes around demonstrating with placards stating "Help Stamp Out Epoxy," I do believe that its indiscriminate use produces a model that is unnecessarily heavy and with the advent of the five minute stuff its use has gotten somewhat out of control. It does, however, have its undisputed place such as in and around the motor



The Avanti makes possible truly low speed approaches with a minimum of attention required on the elevator, and landings that flare out beautifully.

ribs. In order to prevent gluing the wing to the jig blocks, line the interface with small pieces of wax paper. Cut out the trailing edges to the shape shown — they have a constant cross section and therefore can be cut on a table saw.

Put your glue guns away for awhile and start by pinning the trailing edge to the jig blocks. It should be **straight** and directly over the location shown on the plan. Double check this with a square before proceeding. Locate and pin ribs R2, 5, 8, and 11, to the jig blocks and to the plan just forward or aft of the spar notches. You should now be able to lay in the upper wing spar and the 3/8" square leading edge and, if all has gone according to plan, the leading edge should be straight and in contact with all the rib notches. If not, send a strong letter to Don Dewey — otherwise proceed by pinning the leading edge to the ribs.

Locate and pin the rest of the ribs in the same manner. When all is go, remove the wing spar. Remove R2 only and glue it to the leading and trailing edge repinning it to the leading edge and to the jig block. When pinning the rib down to the plan, make sure that it is in contact and square with the building surface. Proceed in the same manner, one at a time, with ribs R5, 8, and 11, then all the others. Glue R1 to the leading and trailing edge at an **angle** to the building surface using the wing dihedral jigs shown on the plan.

Glue in the upper wing spar doubler and the upper main spar making sure it's flush with the top surfaces of the ribs.

When dry, sand away any projections and carefully sand the upper surface of the leading edge flush with the ribs to the shape shown on the rib outlines. Glue on the 3/32" trailing edge sheeting and after wetting the external surface of the leading edge sheeting, glue it in place. Do not sheet the center section yet. Add all the upper capstrips to R5 through R11 and let dry thoroughly.

Remove the wing panel from the building surface, saving the wing dihedral jigs and jig blocks for the opposite panel. Turn the wing over and, using epoxy, install the landing

gear mount so that it protrudes 3/32" above the ribs. Then install the 1/16" ply reinforcements and the maple landing gear torsion block.

Following the same procedure as in the three previous paragraphs, install the leading and trailing edge sheeting and the capstrips to the bottom of the wing. Trim the sheeting overhang flush with R1 and R11 and, after **rough cutting** the tip block, hollow it out and glue it on.

Build the opposite wing panel in the same manner.

JOINING WING PANELS AND AILERONS

Place the bottom of the wing on the work surface and block up the tip rib 1". Using a square sanding block, sand across R1 so that it is square with the work surface. After doing both wings, check for a good fit and, using epoxy, align and join the two panels using two pieces of 1/4" diameter dowel (well vaselined for later removal) inserted in the jig holes in R1.

Remove the center section of R1 by cutting vertically along the forward faces of the main spars and at the rear of the servo compartment, which is shown for a Kraft KPS-10. Vary the location of the rear cut to suit your servo. Glue in the two 1/4" thick balsa gussets from R2 to R2 between the

spars then add the 3/16" rear servo compartment gusset. Using R1 outline, Cut out and install the 3/16" servo compartment side walls. Add the servo mounting rails and complete the top and bottom center section sheeting.

Cut out the ailerons slightly thicker than required but to the correct taper angle. Install the aileron horns using epoxy, make 1 left and 1 right hand. Cut the hinge slots in the ailerons and the wing panels and, using flat hinges, install them on the wing panels without glue. Notch the wing trailing edges as shown to allow forward movement of the horns.

Cut out a piece of hard balsa 3/4" thick to fit between the ailerons and slot it out for clearance with the aileron horns and notch it to allow rearward movement of the aileron horns. Check both ailerons for freedom of motion. Then **tack glue** it onto the trailing edge (for later removal when covering and finishing). The wing is now ready for final sanding. Using lots of masking tape, lock the ailerons in neutral position and sand them, the wing tip trailing edges, and the wing center section trailing edge assembled. After final sanding is completed, apply brush-on epoxy to the wing tips as shown and fiberglass the center section of the wing, top and bottom, about 6" wide and sand smooth when dry.

TAIL GROUP

This is pretty straightforward; however, a few words are in order. When locating the two center ribs on the stab, make sure they are perfectly vertical, square with the trailing edge, and spaced apart for a snug fit with the 3/8" fin. After sheeting top and bottom, sand flush with the tip rib faces and add the tip blocks, then cut out the top sheeting **only** between the center ribs and the leading and trailing edges for the fin extension. Glue up the two elevator halves and while still pinned to the plan, connect them with the 3/32" dia. music wire horn using epoxy.

Prior to contouring the fin and rudder and, likewise, the stab and elevator, cut the hinge slots in all pieces and, using flat hinges, assemble the fin to the rudder, and the stab to



the elevator without glue. Sand to shape and contour as shown. Do not contour the portion of the fin that fits into the stab. Fit and glue the fin into the stab making sure that the fin is square with the stab and that the fin trailing edge is perpendicular to the stab.

FUSELAGE

Cut out the fuse sides, fuse doublers and wing seat stiffeners making sure they're identical. Glue them up, one left hand, one right hand, using contact cement on the fuse doublers and fuse sides. **Accurately** mark all bulkhead locations on the inside surface of both assemblies, and pin them down to the work surface. Make the two motor mount assemblies from 3/8" thick maple and the balsa wedges as shown on the detail, then epoxy them into the slots in the fuse doublers. Cut out and install the 3/16" engine compartment spacers and the 3/16" x 1-5/8" wedges. Now cut out and install all the various pieces of triangle stock with the exception of the vertical 1/2" and 3/4" triangle pieces at F1 and F2. Install the 3/16" x 1/2" longerons to the aft fuse section, the 3/4" trailing edge pieces at the fin and add the 1/16" doublers back there. Using white glue, install the 3/32" thick

plywood dowel reinforcements (undrilled) making sure to allow for the thickness of F3 and F5.

You now have a pair of paddles that don't remotely resemble an airplane fuselage – and heavy? – but have faith – mush on!!! At this point, clamp, pin, or tape the two assemblies together accurately, outside surface to outside surface, and sand the outer edges so that they are straight, square-edged and identical. Stay away from the wing seat curve for now. While the two assemblies are still clamped together, drill them out for the 3/8" wing dowels. Cut out bulkheads F2, 3, 5, 6, 7, and 8. Make sure that F2 and F3 are **exactly** the same width and F5 is 3/8" wider than F2 and F3. This is important since these bulkheads will determine the parallelness of the assembled fuselage. Drill F2 and F3 for the throttle and landing gear linkages and F2 for the fuel lines and nosegear block. Bolt it on now. Glue a couple of 1/4" x 1/4" spreaders to F3 to maintain its width dimension during assembly. These will be removed when the fuse is all built up. Add the 1/8" x 1/2" doublers to the rear of F5, 6, 7, and 8, as shown on the plan.

Pin one of the sides down to the work surface and, using **no glue**, place F2, F3, and F5 in their respective places, then place the other fuselage side on and check for alignment and fit. The two sides should line up and be parallel and square with the building surface. Check the bulkheads for perpendicularity with the sides. When you are satisfied that all is O.K., liberally apply **slow curing** epoxy and Ambroid, as required, to all the flying surfaces of F2, 3, and 5, and the fuselage sides. Reassemble and align everything to make sure they are square and parallel and add a flat weight to the upper fuselage side from forward of F2 to beyond F5. Jig F2 so that it is perpendicular to the fuselage sides. Double check for alignment, squareness and perpendicularity, and let dry overnight. Remove the assembly from the building surface and, using the plan view as a template, taper the mating surfaces of the longerons and the 1/2" x 1/2" triangles at the rear of the fuselage to the

text to page 76

THE ACRO-STAR
 THE SENSATIONAL BIPE DESIGNED BY DON DEWEY AND LEE RENAUG AND FEATURED IN RCM APRIL 1972

UNIQUE SEAMLESS FIBERGLASS FUSELAGE SHELL WITH BULKHEADS AND DOUBLERS
 PRECISION MACHINED PARTS

PRE COVERED GLASKIN WINGS
 COMPLETE HARDWARE PACKAGE

870 SQUARE INCHES
 50 INCH SPAN
 #1 ENGINE
 7 1/2 LBS.

\$89.95
 SEE YOUR DEALER OR ORDER DIRECT

FIBERGLASS FUSELAGE.
 PRE-COVERED GLASKIN WINGS. EXCLUSIVE FIBERGLASS COVERED FOAM CORE.
 PRECISION MACHINED WOOD PARTS.
 COMPLETE HARDWARE PACKAGE.



Joe Budick's
SUPER KAOS

FIBERGLASS FUSELAGE
 With Vertical #1 & Engine Mounts
 All Necessary Wood & Hardware

GLASKIN WING
 Contest Proven

645 sq. Area
 58 1/2 in. Span
 #1 Engine
 22 lbs. wt.

\$79.95

ARF SYSTEMS / 23326 Ladrillo St., Woodland Hills, Calif. 91364 / (213) 883-7999

AVANTI

from page 27

required angle. Place the fuselage assembly (from F5 aft) on the plan (right side up) with the centerline of

F5 coincidental with the centerline on the plan. Check the fuselage sides for perpendicularity with the building surface and jig the forward fuselage section so that it is centered over the plan. Now glue the aft end of the sides together, jiggling them perpendicular to the work surface. Install bulkheads F6, 7, and 8, making sure the fuselage curvature follows the outline and let dry.

Remove the assembly from the work surface and add the 1/8" sheeting (crossgrain) to the bottom of the **to page 78**

BUY DIRECT 25% OFF

BERNIE ASH

DOPE - IT DECALS

*** STICKS TO MONOKOTE! SOLARFILM! AND ALL FINISHES ***
*** DOPE PROOF * FUEL PROOF * SELF ADHESIVE * EASY TO APPLY * TOUGH ***

U.S.A. Red Bars Current		Royal Flying Corps WW I		Military Markings 2 ea.	
Size	Rt. Pr.	Size	Rtl. Pr.	Dsct. Pr.	Colors Red, Wh, Bl, Bk Yl.
5 11/16"	\$5.50	5 1/2"	\$6.95	\$5.21	RAF 3 5/8"
4 7/16"	\$4.49	3 7/8"	\$4.49	\$3.37	USAF 3 1/2"
3 1/2"	\$3.50	\$2.62	French		USAF 2 5/8", NAVY 2 3/8"
2 1/4"	\$1.49	\$1.12	German		USAF 1 1/2", NAVY 1 1/2"
					MARINES 1 1/4"
					U.S. ARMY 1 1/2"
					73¢ number Rtl. \$1.98
					64¢ or Let. Rtl. \$2.49
					56¢ each bottom of wings & fuselage.
					45¢ number Rtl. \$16.95
					34¢ or let. To order specify size, country & color. Send check or money order, in USA add 35¢ postage, outside USA \$1.00. Many items not listed. Send \$1.00 for full color brochure & sample. For club decal emblems send art work for est.

FUEL PROOF

DOPE PROOF

USA 101A

FUEL PROOF

DOPE - IT - DECALS

2550 FAIRFAX RD., INDIANAPOLIS, IND. 46227

317-784-1139

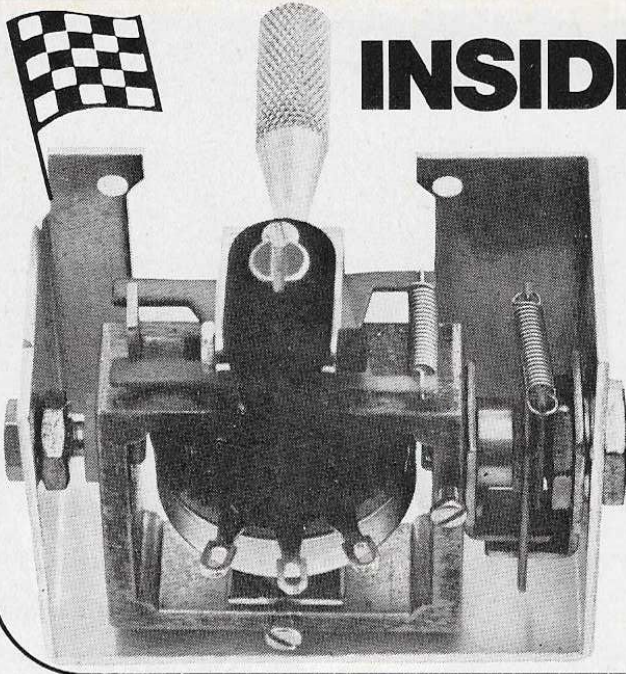

INSIDE PRO LINE...

You are looking at the open gimbals designed by Ron Chidgey used in Pro Line's Competition Series. Precision machined parts with bearing supports opposite all control pots remove play and friction beyond the vanishing point for unparalleled smoothness! Just one of many features that puts Pro Line RC Equipment in the winner's circle—consistently.

PRO LINE ELECTRONICS

10632 North 21st Ave., Suite 10, Phoenix, Az. 85029

SEND FOR FREE PRO LINE DATAPAC TODAY!

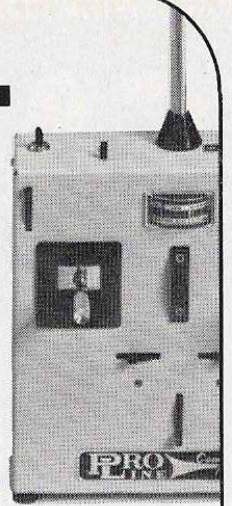

NAME _____
 ADDRESS _____
 CITY/STATE/ZIP _____

AVANTI

from page 76

fuselage. Cut out F4B without notches and install it with the 3/16" aft deck piece. Next, glue together the 3/8" and 3/16" planks that make up the

forward top deck; then make the 60 degree angle cut at the rear for F4B. Hollow it out for the fuel tank as shown, and glue it to the fuselage, then cut out F4A (oversize) and tack glue it to F4B for later removal when fitting and installing the canopy. Check the spacing between the motor mount with your motor. If you have

to do any filing to fit, do it now. Cut out the side nose blocks and epoxy them to the motor mounts and F2, after determining which side the one that's slotted for the steering gear arm goes on. Fit the bottom nose block and glue it in place between the side nose blocks, then add the 3/8" balsa
 to page 82



PRATHER PRODUCTS

NEW! action model
 1:8 scale
LAND SAILER \$19⁹⁵

Assembles in 1 hour

- No Drilling
- No Cutting
- No Soldering
- No Gluing

Race it on any school yard or parking lot.

Radio control or runs free with the wind. No fuel or engine needed.

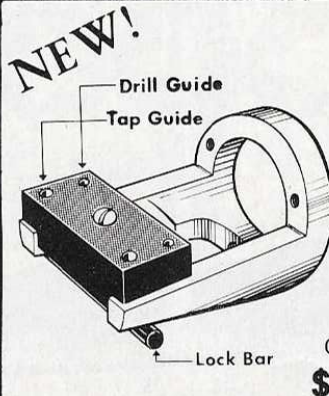

DRILL JIG

No more goofed up motor mounts or egg shaped holes in your engine cases when you use the drill jig and tap guide.

Save only one motor mount or engine case and the drill jig will pay for itself.

Available for the following engines:

VECO - 61	ST - G21 35 - 40 - 46	ENYA - 60
VECO - 19	ST - G60 Blue Head	HP - 61
K & B - 40	WEBRA - 61 Black Head	HP - 40
K & B - 15	OS - 60 Gold Head	OS - 40

Made of a case hardened steel block

NEW! LAND SAILER RACING BODY \$4⁹⁵

Streamline your land sailer - gives it the racy look.

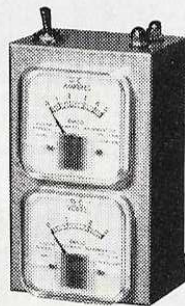
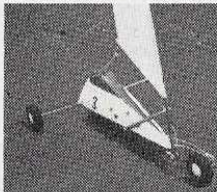

ALL-IN-ONE TESTER

Starting Battery ■ Plug Tester ■ Battery Tester
 Without Removing Plug

- Gives check on condition of Plug
- Gives check on condition of Battery

No more trying to start your engine with a bad plug or a dead battery.

The All-in-one Tester saves time on the starting line. Lets you spend more time in the air. Complete with rechargeable Ni-Cad Battery.

Time Saver for the Sport Flyer **\$29.⁹⁵**

For best service see your local dealer for our products. If not available order direct. Add 50¢ for postage, (\$1.00 outside the U.S.A.).



PRATHER PRODUCTS

1660 RAVENNA AVE., WILMINGTON, CA 90744

MINI HINGE POINT



6 for 89c
15 for \$1.79

HINGE POINT DRILL JIG



\$2.98

WITH SPECIAL DRILL

THE HINGE POINT DRILL JIG AUTOMATICALLY FINDS THE CENTER, GUIDES THE DRILL TO INSURE PERFECT HINGING.

HINGE POINT

TYPICAL INSTALLATIONS



PLASTIC "ARF"



SCALE BUILT UP



FLAP



AILERON



BALSA FOAM

6 for 95c
15 for \$1.95



FLAP EXTERNAL HINGE POINT

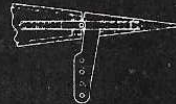

HORNY HINGE POINT

HORNY HINGE POINT



4/79c

(A HINGE POINT WITH A HORN) EASIEST TO INSTALL
Drill 1/8" hole and insert with glue

HINGE POINT FLATS

* PRICED RIGHT!
* DESIGNED BY MODELERS FOR MODELERS



6 for 79c
15 for \$1.49

SEE YOUR DEALER NOW!

robart

P.O. BOX 122 WHEATON, ILL. 60187

AVANTI

from page 78

battery compartment block to the fuselage. Square off and sand the front face of the fuselage to the 1 1/2 degree downthrust angle. Cut out F1 and,

using your spinner as a gauge, taper it as shown, and temporarily install it with the motor, using 1 1/2 degree shims. Drill out the mounts and bolt the motor down and, with the spinner and prop in place, locate and glue F1 to the fuselage (not the motor). Let it dry this way; then remove the motor, prop, and spinner. Now, add the 1/2"

and 3/4" triangles (trimmed to shape) to the rear of F1 and to the forward face of F2 and F5.

You can now get out your old World War II machete, or your favorite ax, and start chopping away at this 10 pound crate. Sand the fuselage to the contours shown on the plan. Go to page 86

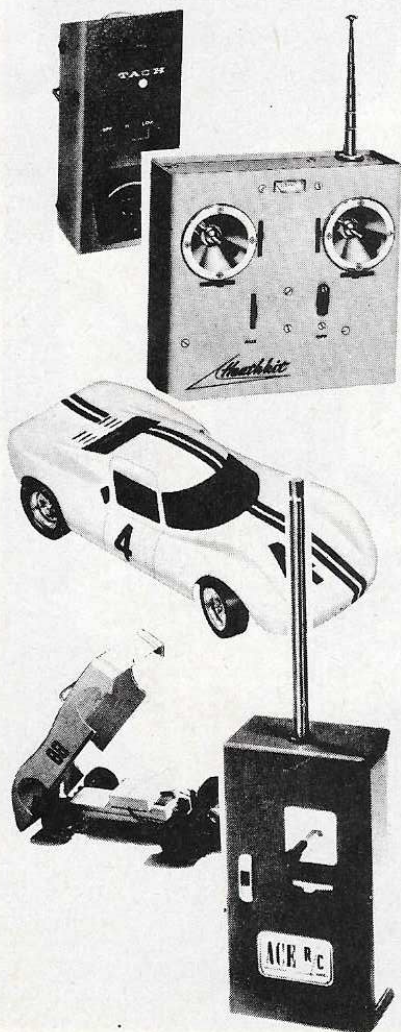

MACS 74

MODEL AND CRAFT SHOW

TWO BIG "Action" DAYS
MAY 11th & 12th
OVER 200 EXHIBITORS

Indoor and Outdoor Demonstrations
Radio Controlled Planes, Cars, Boats,
Helicopters Gliders, Rockets and Plastics

CONTEST OPEN TO THE PUBLIC

Over 57 Categories with trophies, awards and prizes in each. NO FEE. Check local dealer for details.

HOURS: SAT 10 AM - 8 PM SUN 11 AM - 6 PM

Admission: 2.50 Adults 1.50 Jr. (under 18) Under 6 Free

SAVE 50% WITH FREE DISCOUNT TICKETS
AVAILABLE AT ANY LOCAL HOBBY SHOP



800 West Katella Ave., Anaheim, California
NEXT TO DISNEYLAND

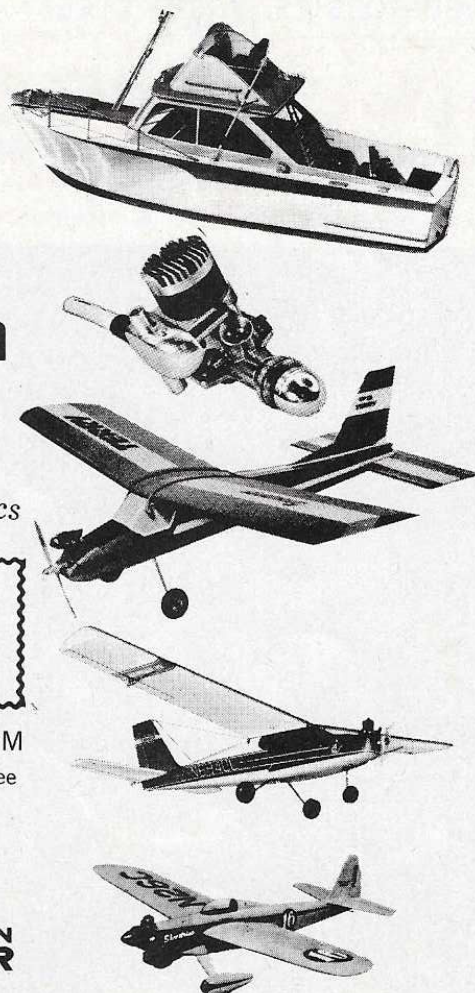

HOBBYPOXY beauty is more than skin deep!

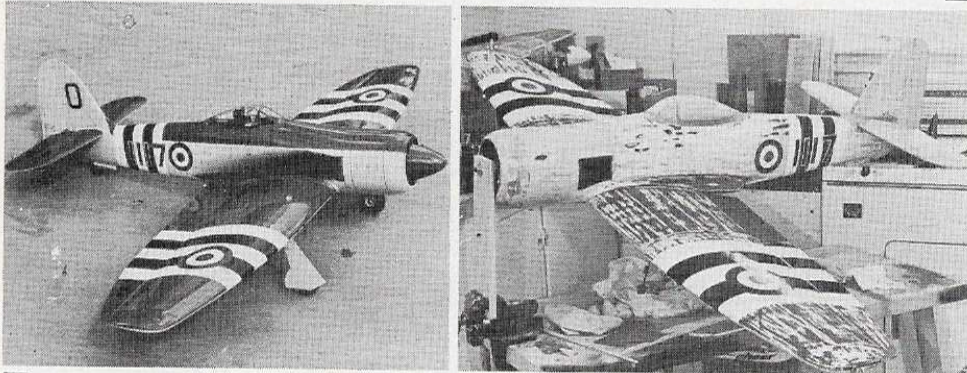

Al Rabe, national control line aerobatics champion in 1972 and 1973, chose Hobbypoxy enamels because he wanted a shiny, durable, fuel-proof finish... which he got. But when he crashed his Sea Fury prior to the '72 Nats, he discovered another advantage of Hobbypoxy paints; reparability. Here's how he tells it:

"The crash destroyed the nose back to the leading edge of the wing. I built an entirely new nose, grafted it onto the fuselage, then covered the bare wood with .001" fiberglass cloth, using Formula II glue. Next, rather than my usual talc-dope filler, I decided to use Hobbypoxy enamel, in the proper color, as a filler as well as a top coat. The reason for this decision is that Hobbypoxy enamels fill fast and sand beautifully! And, in addition, because there's no shrinkage there is no settling of the finish weeks later, as occurs with dope.

"I brushed on four or five coats of color, wet sanded down to the cloth, then applied three more brush coats. After a final sanding I sprayed the last coat with an airbrush. When finished the damage was undetectable, and the total repair added no weight! Let's see somebody try a similar repair using any other product, epoxy or dope. I know it won't be as good because I've tried them.

"Later, because of the success of the repair, and some design changes I wanted to make, I rebuilt and completely refinished the model. Again, sandability of Hobbypoxy was the key factor in my decision to rebuild the airplane.

"As far as I'm concerned, until some other product comes along that's superior... and it hasn't yet... I'm going to continue using Hobbypoxy exclusively."

You should too. Especially if you crunch one now and then. For full information on painting... and repairing... send for our free "Hobbypoxy Painting Pointers" booklet.

HOBBYPOXY PRODUCTS

A Division of Pettit Paint Co., Inc.
36 Pine Street, Rockaway, N.J. 07866



Wing Span 72 in
Wing Area 480 in²
Weight 20 oz
Surf. Loading 5.6 oz/ft²

Drifter

WITH SO MANY MACHINED PARTS & SUCH DETAILED INSTRUCTIONS, TO FAIL WOULD REQUIRE DESTRUCTIVE INGENUITY!

SEE YOUR DEALER FIRST!

RETAIL ORDERS SHIPPED POSTPAID

Calif. Res. add 5% tax
NO C.O.D. PLEASE

Craft-Air

\$24.95

DEALER AND JOBBER
INQUIRIES INVITED

Value Engineered Products

5651 Kelvin Avenue, Woodland Hills, Calif. 91364

AVANTI

from page 82

slowly at F1 and where the canopy joins the fuselage, especially at the forward end.

For a neat canopy installation, set it in flush with the turtledeck and with the sides of the fuselage. Remove bulkhead F4A which was supposed to be only tack glued - remember? Sand it down so that it's smaller than F4B by the thickness of the canopy material, then glue F4A on permanently. Likewise, undercut the 3/16" thick fuselage flat deck by the canopy material thickness.

FINAL ASSEMBLY

Carefully sand the wing seat to fit the wing contour. Then install the 3/8" wing dowels and assemble the wing to the fuselage, aligning for squareness, equal distances from ribs R11 to fuselage, and from the tips to the centerline of the fuselage at the rear and all those good things. While still assembled, cut out and fit the balsa wing fairing block and glue it to the wing, then sand it to the fuselage contour. With the wing still accurately located, add the tail group to the fuselage, again, checking for all those good things. Double gluing this joint is mandatory if you're not a believer. Add the fin fairing blocks to both sides of the fin and sand to shape.

FINISHING

There have been so many words written on this subject and there are so many options I won't go into details. However, some general instructions regarding the hidden aileron horns, are in order.

Detach the wing center section trailing edge that was tack glued on and remove the ailerons. Then tack glue it on again and cover and COMPLETELY finish the wing. After covering and finishing the ailerons, white glue or epoxy the hinges to them. To install the ailerons, NEATLY slit the top covering only of the wing center section trailing edge at the wing trailing edge and hinge it out of the way. Vaseline the aileron horn slot liberally, install both ailerons and epoxy the center section trailing edge to the wing.

BALANCING

Install all flight equipment except the elevator, rudder, and motor servo tray. Turn the bird upside down and tape the servo tray with servos to the

to page 90

Did you know R/C Sailing can be highly competitive, or just plain fun?

Did you know Your present R/C equipment can be used without change?

FOR THE AMYA 36/600 CLASS

TAHOE 600

Length 36 in
Beam 9 1/4 in
Sail area 600 sq in

- MOLDED PLASTIC CONSTRUCTION
- FINISHED NYLON SAILS
- COMPLETE KIT (LESS BALLAST)

\$35.95 p.p.d.

VICTOR SAIL SYSTEM

FOR MODELS WITH UP TO 600 sq in
SAIL AREA \$24.95

VICTOR MK II SAIL SYSTEM

FOR VALKYRIE SIZE MODELS
(AVAILABLE APPROX MAY 15)

At your dealer or
direct from;

VICTOR MODEL PRODUCTS

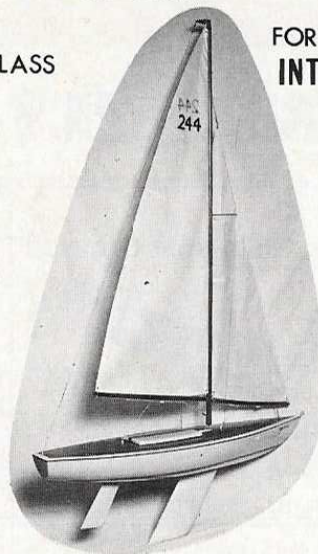

FOR THE AMYA 50/800 CLASS
INTRODUCING!

VALKYRIE

(shown)
Length 50 in
Beam 11 1/2 in
Height 74 1/2 in
Sail area 800 sq in
Displ. 14 1/2 lbs (less R/C)

- MOLDED PLASTIC CONSTRUCTION
- FINISHED DACRON SAILS
- COMPLETE KIT (LESS BALLAST)

\$74.95 p.p.d.

COLORED NYLON SAIL SETS AND
LEAD SHOT BALLAST AVAILABLE

Dealers welcome

13042 Premiere Ave
Downey Ca. 90242

Calif residents
please add
sales tax

All versions of the "Avanti" were powered with Enya .60's, the first three with the .60 II and the current one with the .60 III. The increased power of the .60 III, coupled with the 100 oz. (6 1/4 lb.) flying weight of the current version, produces a delightfully lively bird that goes through its maneuvers in a manner that can best be described as graceful. It can be flown slowly without "falling out of the sky" and, conversely, will climb vertically until practically out of sight.

While the Winter evenings devoted to designing and building are an important part of the hobby to me, the gratification of flying a unique model is really where it's at. The "icing on the cake," however, will come from knowing that the "Avanti" has given some enjoyment to those of you who decide to build it. I will be happy to answer your questions and sincerely look forward to your comments. Have fun!!!

AVANTI

from page 86

wing at the approximate position shown. The balance point should be on the line of the landing gear wires where they run along the wing. Move the servos until this balance point is reached and, if necessary, move the battery pack in its compartment. When the proper balance point is

reached, install the servo mounting rails and install the servo tray. Check for side to side balance and, if necessary, add the required tip weight.

FLYING

The control surface movements shown on the plan are "as measured" from my bird and were derived by adjusting until they suited me. As specified, they afford more than adequate control and even if such is not your preference, it is desirable on initial flights to have a reserve for trimming.

HONKER BIPE!

featured in march '74 rc modeler

\$32.95
see your dealer
or order direct
(postpaid)



Another unique HAND-CRAFTED kit by Southwestern Sailplanes. Same high quality machined balsa and ply parts; same hand-built, hand-sanded, ready-to-finish wing panels; same complete hardware package, including pushrods and formed landing gear (wheels not included.)

SPAN-36" AREA-500" ENGINE-09 to 25 c.i.

SWS

SOUTHWESTERN SAILPLANES
917 Princeton SE Albuquerque NM 87106

photography by
Max & Gloria Mills